

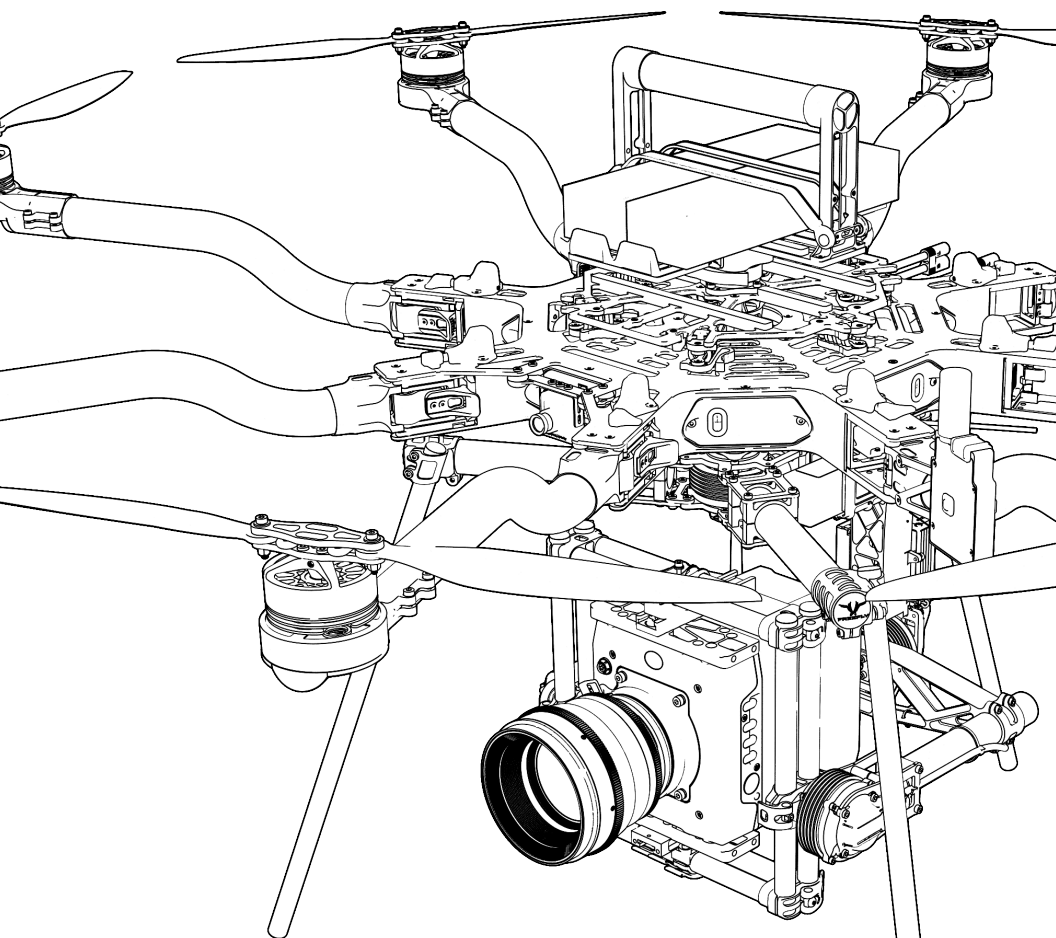

# ALTA 8



## AIRCRAFT FLIGHT MANUAL

770-00048 | REVISION C | 05.10.2019

# REVISION HISTORY

---

| REVISION | DATE         | DESCRIPTION  |
|----------|--------------|--|
| A        | March 2016   | Initial Release  |
| B        | January 2017 | Added discussion of features available in SYNAPSE version 4.0.4. Added Kinematic Position Mode. Added Orbit Mode. Updated Alarm Light scenarios. Added procedure to disable ceiling and range limits. Updated Autoland descent rate. Updated default settings, switch functions, and data logging fields. General updates and typographical fixes. |
| C        | May 2019     | Additional material added to system specification  |

# CONTENTS

---

|    |   |
|----|---|
| 2  | Revision History                              |
| 3  | Contents                                      |
| 5  | <b>ALTA 8 OVERVIEW</b>                        |
| 6  | Disclaimer and Warning                        |
| 8  | LIMITATION OF LIABILITY                       |
| 9  | Introduction                                  |
| 10 | Symbols, Abbreviations, and Terminology       |
| 13 | Dimensions                                    |
| 15 | Included Items                                |
| 16 | Specifications                                |
| 21 | Limitations                                   |
| 24 | System Diagrams                               |
| 28 | ALTA Mobile App                               |
| 29 | Additional Required Components (not included) |
| 30 | <b>SETTING UP ALTA 8</b>                      |
| 31 | Unfolding ALTA 8                              |
| 34 | Radio Installation                            |
| 39 | Radio Channel Mapping                         |
| 45 | Configuring for MōVI                          |
| 47 | Isolator Cartridges                           |
| 48 | Battery Installation                          |
| 53 | Compass Calibration                           |
| 56 | Propellers                                    |
| 58 | First Person View (FPV)                       |
| 62 | FPV On Screen Display Setup                   |
| 65 | Tuning ALTA 8                                 |
| 69 | ALTA 8 Flight Parameters                      |
| 73 | Resetting ALTA 8 WiFi Password                |
| 74 | <b>OPERATING ALTA 8</b>                       |
| 75 | Flight Controller Modes                       |

|    |                      |
|----|----------------------|
| 80 | Home switch          |
| 81 | Orbit switch         |
| 82 | Disarm Safety Switch |
| 83 | Status Light         |
| 85 | Orientation Lights   |
| 86 | Alarms               |
| 87 | ALTA App Monitor     |
| 88 | Data Logging         |

## 89 **NORMAL PROCEDURES**

|    |                     |
|----|---------------------|
| 90 | Unpacking and Setup |
| 91 | Before Starting     |
| 93 | Before Takeoff      |
| 95 | After Every Flight  |
| 97 | After Last Flight   |

## 98 **EMERGENCY PROCEDURES**

|     |  |
|-----|--|
| 99  | Emergency Guidance                             |
| 100 | Alarm Indication (Flashing or solid red light) |
| 102 | Unexpected Flight Controller Behavior          |
| 103 | Battery Exhaustion                             |
| 104 | Radio Loss of Signal (LOS)                     |
| 105 | Loss of FPV Signal                             |

## 106 **PERFORMANCE**

### 109 **MAINTAINING ALTA 8**

|     |                                    |
|-----|------------------------------------|
| 110 | General Information and Techniques |
| 111 | Maintenance Items                  |
| 114 | Replacement of Parts               |
| 115 | Firmware Update Process            |

## 120 **TROUBLESHOOTING**

### 125 **APPENDIX**

|     |                                   |
|-----|-----------------------------------|
| 126 | Appendix A. Default Tuning Values |
| 127 | Appendix B. Data Logging Fields   |



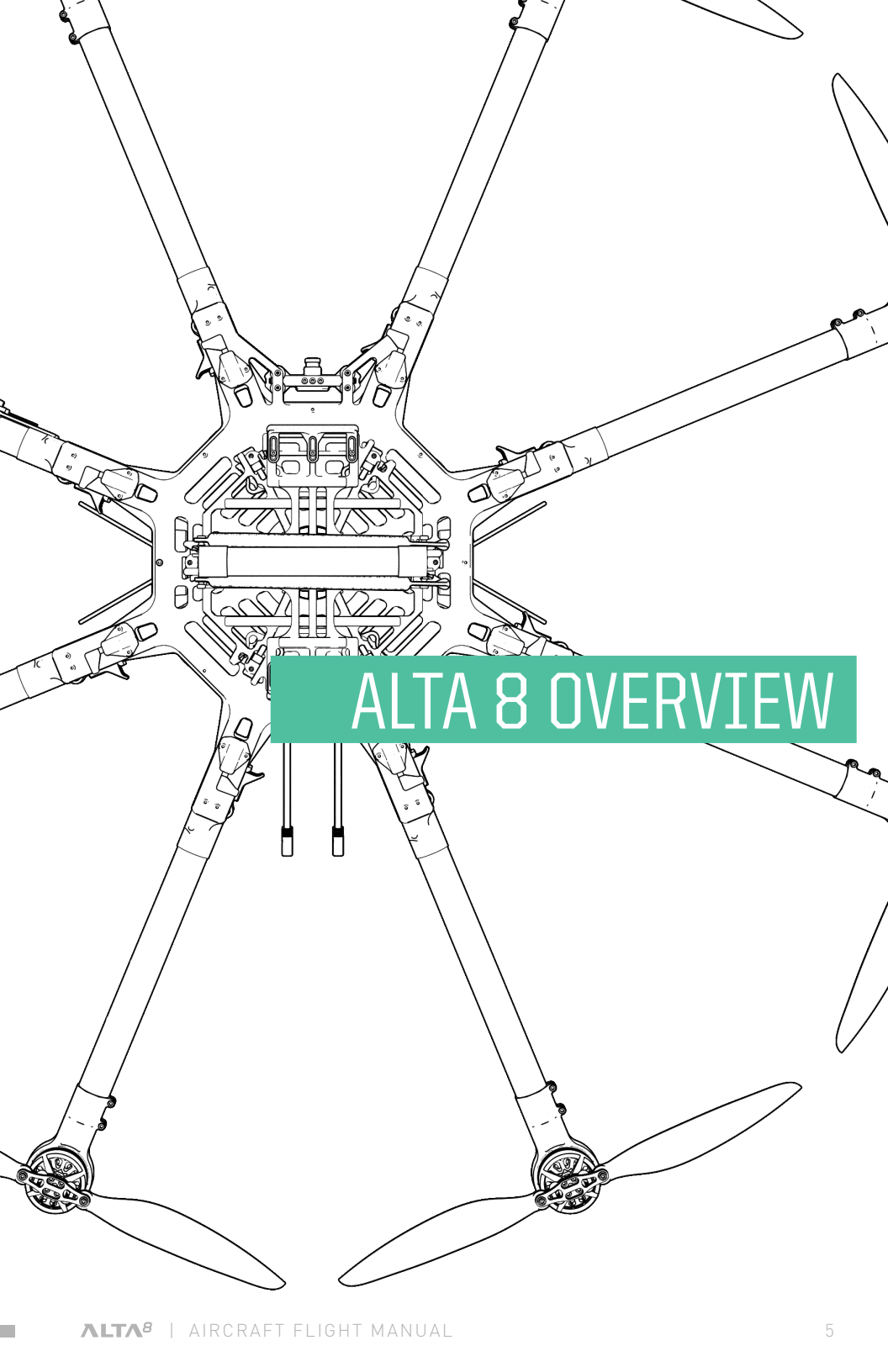

# ALTA 8 OVERVIEW

# DISCLAIMER AND WARNING

**IMPORTANT** - Please read this disclaimer and warning carefully and review the ALTA 8 Aircraft Flight Manual (AFM) prior to flight. If you have any questions, please contact [support@freeflysystems.com](mailto:support@freeflysystems.com) prior to using the ALTA 8. You can review the most current version of this AFM at [www.freeflysystems.com/software-manuals/](http://www.freeflysystems.com/software-manuals/).

By using ALTA 8, you acknowledge that you have read, understand and agree to this disclaimer. You agree that you are solely responsible for your conduct while using ALTA 8, and for any direct or indirect consequences that may result from its use. You agree to only use ALTA 8 for proper purposes that are in accordance with local and airspace rules and regulations.

- » ALTA 8 is not a toy and should be operated with extreme care, as improper operation can cause damage to property, serious personal injury or death.
- » As with any multi-rotor aircraft, ALTA 8 is a complex and technical machine. Novice pilots should invest sufficient time on a flight simulator and seek training from an experienced pilot prior to operation. The ALTA 8 Aircraft Flight Manual and a flight simulator are no substitute for training with an experienced pilot, particularly when it comes to learning how to safely operate ALTA 8. Novice pilots should never fly without the supervision of an experienced pilot.
- » Always check ALTA 8 and its components prior to operation.
- » Always maintain a safe distance from ALTA 8 when in use.
- » Never attempt to touch ALTA 8 when the propellers are moving.
- » Never fly ALTA 8 over or around people, power lines or other aircraft.
- » Never fly with any propellers that have visible imperfections or damage.
- » Always keep children and animals a safe distance away from ALTA 8 when in use and when changing configurations.
- » Only use propellers supplied by Freefly Systems that are designed for use on ALTA 8.
- » Always remove the propellers or power ALTA 8 using a low power source when making a change to the configuration of ALTA 8 to prevent propeller strikes in the event of unintentional motor starts.
- » Always remove the configuration jumper when making changes to the configuration of ALTA 8.
- » Always test ALTA 8 with the propellers removed to make sure that the motors are spinning in the correct direction and that the motor assignment is correct with respect to the Synapse flight controller. If you have either of these wrong, the ALTA 8 will be uncontrollable and dangerous.

- » It is your responsibility to perform a full system check of ALTA 8 prior to every flight.
- » It is your responsibility to learn how to safely operate ALTA 8 and to adhere to all applicable rules and regulations.
- » Fly at your own risk.
- » ALTA 8 is a tuned system with custom components selected for each application. Modification to, removal, or substitution of ALTA 8 components will void the warranty and can lead to unsafe operating conditions.

## LIMITATION OF LIABILITY

IN NO EVENT SHALL FREEFLY BE LIABLE TO BUYER FOR ANY INDIRECT, CONSEQUENTIAL, PUNITIVE, INCIDENTAL, OR SPECIAL DAMAGES, OR ANY DAMAGES WHATSOEVER RESULTING FROM THE USE OF ALTA OR FROM LOSS OF USE, DATA OR PROFITS (HOWEVER CAUSED AND UNDER ANY THEORY OF LIABILITY), EVEN IF FREEFLY HAS BEEN ADVISED OF THE POSSIBILITY OF SUCH DAMAGES. IN NO EVENT SHALL FREEFLY'S LIABILITY FOR A PRODUCT (WHETHER ASSERTED AS A TORT CLAIM, A CONTRACT CLAIM OR OTHERWISE) EXCEED THE AMOUNTS PAID TO FREEFLY FOR SUCH PRODUCT. NOTWITHSTANDING ANYTHING HEREIN, IN NO EVENT SHALL FREEFLY'S LIABILITY FOR ALL CLAIMS ARISING OUT OF OR RELATING TO THIS AGREEMENT EXCEED THE AMOUNTS PAID BY BUYER TO FREEFLY FOR PRODUCT IN THE LAST TWELVE (12) MONTHS. IN NO EVENT WILL FREEFLY BE LIABLE FOR COSTS OF PROCUREMENT OR SUBSTITUTE GOODS BY BUYER. THE LIMITATIONS SET FORTH HEREIN SHALL APPLY TO ALL LIABILITIES THAT MAY ARISE OUT OF THIRD-PARTY CLAIMS AGAINST BUYER. THESE LIMITATIONS SHALL APPLY NOTWITHSTANDING ANY FAILURE OF ESSENTIAL PURPOSE OF ANY LIMITED REMEDY.

Freefly shall not be liable for damages or injuries incurred directly or indirectly from the use of ALTA 8 including, but not limited to, the following situations:

- » Failure of operator to follow proper instructions and safety warnings found at [www.freeflysystems.com](http://www.freeflysystems.com).
- » Failure of the operator to understand and operate the aircraft within the operating limitations described in this manual.
- » Failure of the operator to follow onboard safety warnings while using ALTA 8.
- » Failure of the operator to follow and comply with local rules and regulations.
- » Failure of the operator to inspect ALTA 8 and its components prior to operation.
- » Failure of the operator to properly maintain and/or service ALTA 8 through an authorized Freefly Service Center with genuine ALTA 8 parts.
- » Use of third-party products on ALTA 8.
- » Use of ALTA 8 in a physically or mentally impaired capacity.
- » Use of ALTA 8 without sufficient training.
- » Use of ALTA 8 in unsafe conditions, including but not limited to, bad or severe weather, such as rain, wind, snow, lightning, dust storms, etc., or in areas of magnetic or radio interference, such as power stations, broadcasting and cell phone towers, government prohibited airspace, etc.
- » Improper operation, misjudgment or risky behavior while using ALTA 8.
- » Infringement of third party data, audio, or video rights recorded when using ALTA 8.

# INTRODUCTION

---

ALTA 8 is a professional multi-rotor aircraft designed for demanding cinematic, television, and photographic applications. Within five minutes, ALTA 8 can unfold from its carrying case to flying some of the most capable cinema cameras on either the top or bottom of the aircraft. The SYNAPSE flight controller is purpose-built for cinema use, yielding precise yet smooth control.

This Aircraft Flight Manual has been prepared to describe the complete operation of airframe and flight control systems, and the normal maintenance of those items. Do not operate ALTA 8 without reading and understanding this manual.

This manual is not a substitute for adequate flight training. Training requirements can vary when operating in different countries or under different flight conditions. Always consult local regulations before flying ALTA 8. In areas where there are no flight training requirements, it is the sole determination of the pilot-in-command as to whether he or she has the appropriate level of training or experience for a given flight. Always set and adhere to personal minimums and fly within your own capabilities.

# SYMBOLS, ABBREVIATIONS, AND TERMINOLOGY

## WARNINGS, CAUTIONS AND NOTES

Throughout the manual, warnings, cautions and notes are used to highlight various important procedures. These are defined as follows:



**WARNING**

Warnings are used to highlight procedures which, if not strictly observed, may result in personal injury or loss of life.



**CAUTION**

Cautions are used to highlight procedures which, if not strictly observed, may cause damage to equipment.

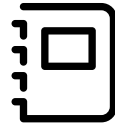

**NOTE**

Notes are used to highlight specific operating conditions or steps of a procedure.

## METEOROLOGICAL TERMINOLOGY

|     |  |
|-----|--|
| ISA | International Standard Atmosphere in which:<br><br>The air is a dry, perfect gas;<br><br>The temperature at sea level is 15° Celsius (59° Fahrenheit);<br><br>The pressure at sea level is 1013.2 mbar (29.92 inches Hg);<br><br>The temperature gradient from sea level to the altitude at which the temperature is -56.5°C (-69.7°F) is -0.00198°C (-0.003564°F) per foot and zero above that altitude |
| MSL | Mean Sea Level is the average height above the surface of the sea for all stages of tide   |
| AGL | Above Ground Level is the height of the aircraft above the ground  |
| OAT | Outside Air Temperature is the free air static temperature surrounding the aircraft  |

|                   |  |
|-------------------|--|
| Pressure Altitude | <p>Altitude measured from standard sea level pressure (1013.2 mbar, 29.92 in. Hg) by a pressure or barometric altimeter</p> <p>It is the indicated pressure altitude corrected for position and instrument error. In this Manual, altimeter instrument errors are assumed to be zero</p> |
|-------------------|--|

## POWER TERMINOLOGY

|   |  |
|---|--|
| Maximum Continuous Power Output         | The maximum typical power output of a motor averaged over the entire flight              |
| Maximum Instantaneous Peak Power Output | The maximum power output of a motor during any phase of flight, such as when maneuvering |

## FLIGHT AND POWERPLANT CONTROL

|                                  |  |
|----------------------------------|--|
| Throttle Stick                   | The radio controller stick responsible for throttle control. For Mode 2 controllers, this is the vertical movement of the left control stick. For Mode 1 controllers, this is the vertical movement of the right control stick |
| Yaw Stick                        | <p>The radio controller stick responsible for yaw (also called pan) control</p> <p>For Mode 2 and Mode 1 controllers, this is the lateral movement of the left control stick</p>   |
| Pitch Stick                      | <p>The radio controller stick responsible for pitch control. For Mode 2 controllers, this is the vertical movement of the right stick</p> <p>For Mode 1 controllers, this is the vertical movement of the left stick</p>       |
| Roll Stick                       | The radio controller stick responsible for roll control. For Mode 2 and Mode 1 controllers, this is the lateral movement of the right control stick  |
| Pitch/Roll Stick or Cyclic Stick | <p>The radio control stick responsible for both pitch and roll control</p> <p>For Mode 2 controllers, this is the right stick</p>  |

## WEIGHT AND BALANCE

|                               |   |
|-------------------------------|---|
| Maximum Takeoff Weight (MTOW) | Maximum allowable weight at liftoff                       |
| Standard Empty Weight         | Weight of a standard aircraft                             |
| Basic Empty Weight            | Standard empty weight plus optional equipment             |
| Useful Load                   | Difference between take off weight and basic empty weight |
| Payload                       | Useful load less battery weight                           |

## GENERAL TERMINOLOGY

|      |   |
|------|---|
| LOS  | Loss of Signal  |
| RTH  | Return-to-Home  |
| sUAS | Small Unmanned Aircraft System includes all components of the system required for the flight of an unmanned aircraft, including the radio controller, data link and other related support equipment |



# DIMENSIONS

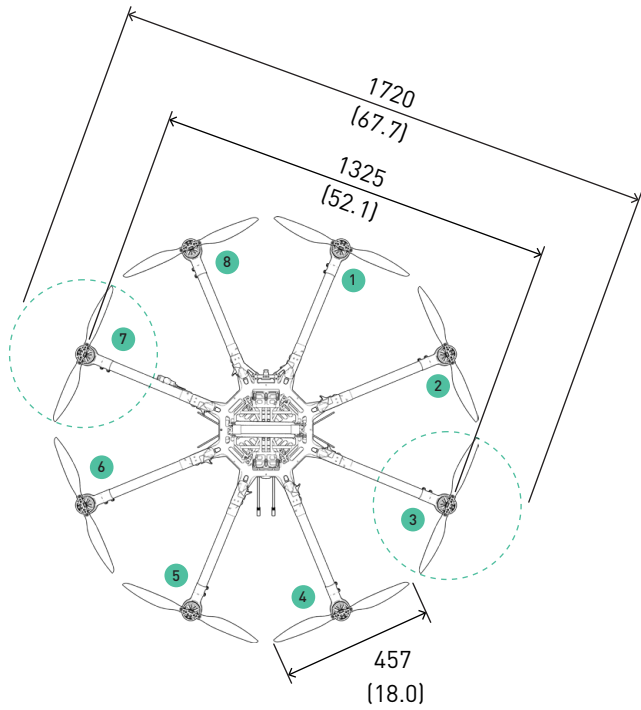

UNFOLDED PLAN VIEW WITH BOOM NUMBERING SCHEME MM (INCH)

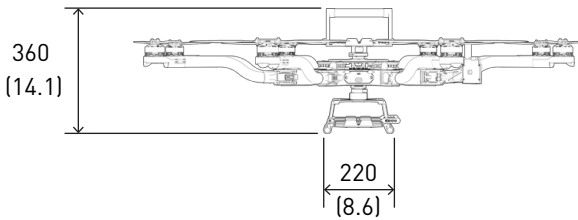

UNFOLDED SIDE VIEW WITH LANDING GEAR MM (INCH)

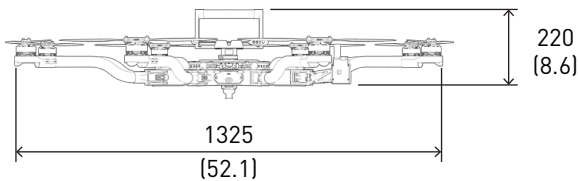

UNFOLDED FRONT VIEW WITHOUT LANDING GEAR MM (INCH)

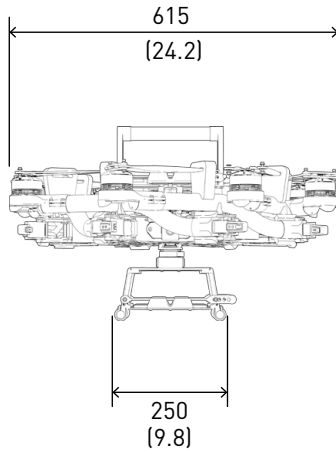

FOLDED SIDE VIEW MM (INCH)

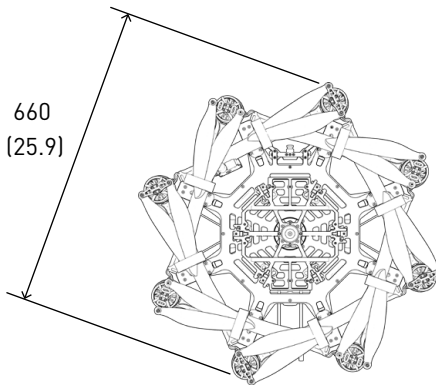

FOLDED PLAN VIEW MM (INCH)

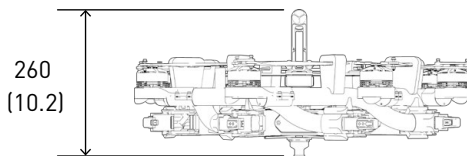

FOLDED FRONT VIEW MM (INCH)

# INCLUDED ITEMS

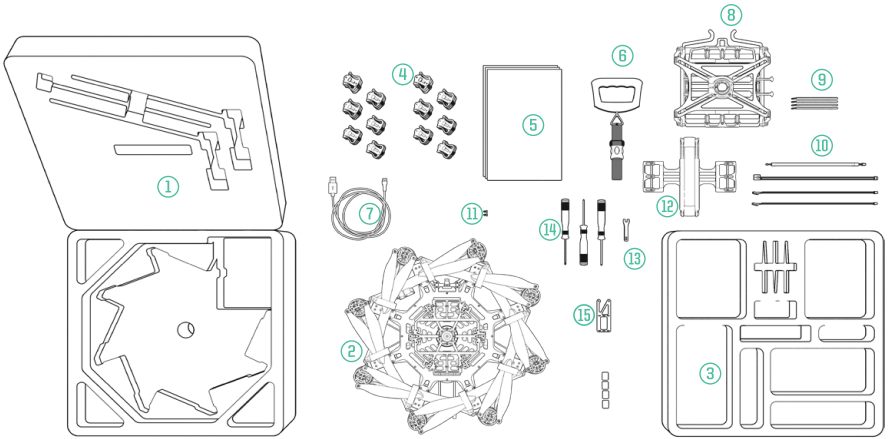

- 1. Case
- 2. ALTA 8
- 3. Case Lid Foam
- 4. Isolator Cartridges
  - a. (6) Teal (Installed)
  - b. (6) Black
  - c. (6) Red
- 5. Documentation
- 6. Electronic Luggage Scale
- 7. USB-Futaba Power Cable
- 8. Inverted Landing Gear
- 9. Antenna Tubes
- 10. FPV Cables
  - a. Skyzone/BOSCAM
  - b. BOSCAM, small connector
  - c. ImmersionRC/Fat Shark
  - d. Ready Made RC
- 11. (2) M3 × 6 Flat Head for Accessory Mount
- 12. Quick Release Battery Tray
- 13. 5.5mm Wrench
- 14. Hex Drivers (1.5mm, 2.0mm, 2.5mm)
- 15. Accessory Mount
- 16. Double-Sided Tape

# SPECIFICATIONS

---

## DIMENSIONS

|   |         |
|---|---------|
| Unfolded Diameter<br>(does not include Props) | 1325 mm |
| Folded Diameter<br>(does not include Props)   | 660 mm  |
| Height to base of Toad In The Hole (TITH)     | 263 mm  |

## POWERPLANT

|  |                                     |
|--|-------------------------------------|
| Number of Motors                             | 8                                   |
| Motor Type                                   | Direct Drive 3-Phase PMAC Outrunner |
| Motor Make and Model                         | Freefly F45                         |
| Motor Max Continuous Power Output            | 350 W                               |
| Motor Max Instantaneous<br>Peak Power Output | 950 W                               |
| Maximum RPM (flat rated)                     | 6300 RPM                            |
| Equivalent Kv                                | 384                                 |
| Electronic Speed Controller                  | Freefly Silent-Drive Sine Wave ESC  |

## PROPELLERS

|                       |                              |
|-----------------------|------------------------------|
| Make and Model        | Freefly ALTA Propeller       |
| Material              | Carbon fiber with balsa core |
| Propeller Orientation | (4) CW and (4) CCW Props     |
| Propeller Type        | 18 × 6 Folding               |

## BATTERY

|   |                            |
|---|----------------------------|
| Nominal Battery Voltage                                 | 6S / 22.2V                 |
| Maximum Battery Size (GroundView)                       | 240 × 175 × 80 mm          |
| Maximum Battery Size (SkyView)                          | 220 x 156 x 64 mm          |
| Maximum Battery Quantity                                | 2 Battery Packs (Parallel) |
| Minimum Battery Quantity                                | 2 Battery Packs (Parallel) |
| Battery Connectors                                      | 2× EC5 (Parallel)          |
| Required Minimum Battery<br>Discharge Rating (Per Pack) | 250A / 500A Peak           |

# WEIGHTS

|  |                    |
|--|--------------------|
| Maximum Gross for Takeoff <sup>1</sup> | 18.1 kg (40.0 lbs) |
| Maximum Useful Load <sup>2</sup>       | 12.0 kg (26.4 lbs) |
| Maximum Payload <sup>3</sup>           | 9.1 kg (20.0 lbs)  |
| Typical Standard Empty Weight:         | 6.2 kg (13.6 lbs)  |

## **WARNING**

---

Always refer to the following aircraft limitations section for complete information on allowable maximum gross weights at different altitudes and temperatures before any flight.

---

# SPECIFIC LOADINGS

|                                     |          |
|-------------------------------------|----------|
| Typical Specific Power <sup>4</sup> | 145 W/kg |
| Thrust Ratio at MTOW <sup>1</sup>   | 1.85 : 1 |

---

<sup>1</sup> At sea level, ISA. Refer to the Weight Limitations section for complete loading information.

<sup>2</sup> Top and bottom mount. Includes batteries.

<sup>3</sup> Payload weight top or bottom mount. Battery weight not included and mounted on opposite side from payload.

<sup>4</sup> At MTOW, sea level, ISA.

---

## FLIGHT CONTROLLER

|  |   |
|--|---|
| Model Name                                   | Freefly SYNAPSE flight controller   |
| Flight Modes                                 | Manual, Height Mode, Position Mode (Classic, Kinematic), Return-to-Home (RTH), Autoland, Orbit Mode |
| Supported Inputs:                            | DSMX, DSM2, S.Bus, S.Bus2, PPM, FPV SD  |
| Supported Radios                             | Futaba S.Bus & S.Bus2, DSMX, DSM2 (Spektrum/JR), PPM, PPM Invert, PPM Graupner                      |
| Supported Radio Controller Telemetry Systems | Futaba w/ built-in voltage sense port   |
| Minimum Radio Controller Channels Required   | 5   |
| Supported GNSS                               | GPS, GLONASS, Galileo   |
| Supported SBAS                               | QZSS, WAAS, EGNOS, MSAS   |
| First-Person View System Video Formats       | NTSC, PAL   |
| Supported First-Person View Transmitters     | Skyzone, BOSCAM, ImmersionRC, Fat Shark   |
| Supported First-Person View Cameras          | Ready Made RC (RMRC-700XVN Recommended)   |
| First-Person View OSD Telemetry              | User Configurable   |
| Installed Transceivers                       | Wi-Fi 2.4 GHz b/g/n   |
| Data Logging Rate                            | 25 Hz   |

## LIGHTING AND INDICATION

|                                 |  |
|---------------------------------|--|
| Status Light                    | 1 Watt Red, 1 Watt White LED                 |
| Orientation Lights              | 3-Watt RGB LED                               |
| Orientation Light Color Options | Red, Yellow, Blue, Purple, Green, White, Off |

## ISOLATION SYSTEM

|                                    |               |
|------------------------------------|---------------|
| Vibration Isolation System         | O-Rings       |
| Option 1: Soft / Light Payloads    | Red O-Rings   |
| Option 2: Medium / Medium Payloads | Teal O-Rings  |
| Option 3: Stiff / Heavy Payloads   | Black O-Rings |

# PAYLOAD MOUNTING

|                       |   |
|-----------------------|---|
| Mounting Locations    | Bottom and Top Mount                          |
| Mounting System       | Freefly Toad In The Hole (TITH) Quick Release |
| FPV Camera Mount      | Between Booms 8 & 1                           |
| FPV Transmitter Mount | Boom 2  |

# CENTER OF GRAVITY

## ALTA8 : Typical Standard Empty Weight

Payload: none Weight: 6.2 kg (13.6 lbs)

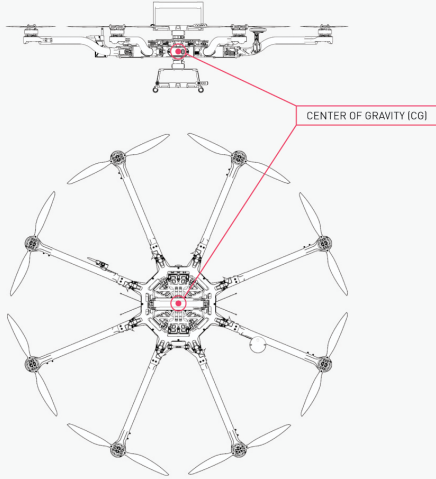

## ALTA8 : Skyview with Max Payload

Payload: 9.1 kg (20.0 lbs) Weight: 18.1 kg (40.0 lbs)

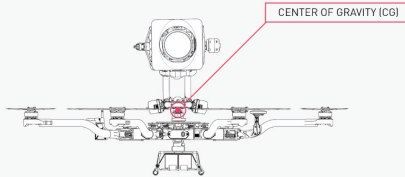

## ALTA8 : Standard with Max Payload

Payload: 9.1 kg (20.0 lbs) Weight: 18.1 kg (40.0 lbs)

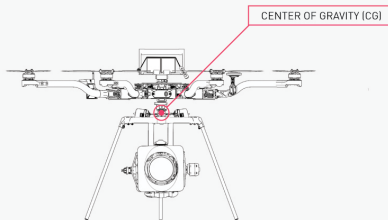

The aircraft is designed with a central mounting point on the top and bottom of the aircraft chassis for payload mounting. This mounting point has been designed to match the Center of gravity of the aircraft, so when using this mounting point it is recommended for optimal flight characteristics to balance the payload to have a matching vertical Center of Gravity.



# LIMITATIONS

---

## NOTE

These limitations are advisory in nature and do not extend or restrict limitations provided by Governing Aviation Authorities.

---

## POWERPLANT LIMITATIONS

|                                 |            |
|---------------------------------|------------|
| Maximum RPM                     | 6300 RPM   |
| Maximum Battery Voltage         | 25.2 Volts |
| Minimum Average Battery Voltage | 19.2 Volts |

## ENVIRONMENTAL LIMITATIONS

Do not fly ALTA 8 in temperatures exceeding 45°C (113°F) or below -20°C(-4°F).<sup>5</sup>

Weather/environmental conditions have an effect on both the pilot and the system. These effects can impact the performance or operating safety of the aircraft. It is important as a pilot or operator of this aircraft to be monitoring weather/environmental conditions and changes at all times and be able to identify when these have an effect on both the pilot and system.

### PILOT EFFECTS CAN INCLUDE THE FOLLOWING BUT ARE NOT LIMITED TO:

- » Reduced pilot visibility (Sun blindness, fog, snow, etc)
- » Cold fingers
- » Heat exhaustion
- » Distractions
- » IMSAFE factors  
(Illness, Medication, Stress, Alcohol, Fatigue, Emotion/Eating)

### SYSTEM EFFECTS CAN INCLUDE THE FOLLOWING BUT ARE NOT LIMITED TO:

- » Cold batteries
- » Propellor icing
- » Damage due to water
- » Wind during flight/landing

## FLIGHT CONTROLLER LIMITS

|                          |               |
|--------------------------|---------------|
| Maximum Pitch/Roll Angle | 45°           |
| Maximum Yaw Rate         | 150° / second |

Maximum flight angle is defined by the flight controller. Maximum velocity is a function of payload and operating conditions. Always operate the aircraft in a safe manner depending on payload and operating conditions.

---

<sup>5</sup>Battery temperature ratings must be observed.

## WEIGHT LIMITS

|                        |                     |
|------------------------|---------------------|
| Maximum Payload        | 9.1 kg (20.0 lbs)   |
| Maximum Takeoff Weight | See following table |

## ALTA 8 ALLOWABLE GROSS WEIGHT

As altitude and temperature increase, the density of the air decreases. Consequently, ALTA 8's thrust will decrease. The following table describes maximum gross weight limits with respect to altitude and temperature.

| Press Alt       | 0°C (32°F)                |                           | 10°C (50°F)               |                           | 20°C (68°F)               |                           | 30°C (86°F)               |                           | 40°C (104°F)              |                           |
|-----------------|---------------------------|---------------------------|---------------------------|---------------------------|---------------------------|---------------------------|---------------------------|---------------------------|---------------------------|---------------------------|
|                 | Maximum Gross Weight (lb) | Maximum Gross Weight (kg) | Maximum Gross Weight (lb) | Maximum Gross Weight (kg) | Maximum Gross Weight (lb) | Maximum Gross Weight (kg) | Maximum Gross Weight (lb) | Maximum Gross Weight (kg) | Maximum Gross Weight (lb) | Maximum Gross Weight (kg) |
| Sea Level       | 40.0                      | 18.1                      | 40.0                      | 18.1                      | 39.3                      | 17.8                      | 38.0                      | 17.2                      | 36.8                      | 16.7                      |
| 305m (1000ft)   | 40.0                      | 18.1                      | 39.3                      | 17.8                      | 37.9                      | 17.2                      | 36.7                      | 16.6                      | 35.5                      | 16.1                      |
| 610m (2000ft)   | 39.2                      | 17.8                      | 37.8                      | 17.2                      | 36.6                      | 16.6                      | 35.4                      | 16.0                      | 34.2                      | 15.5                      |
| 914m (3000ft)   | 37.8                      | 17.2                      | 36.5                      | 16.5                      | 35.2                      | 16.0                      | 34.1                      | 15.5                      | 33.0                      | 15.0                      |
| 1219m (4000ft)  | 36.4                      | 16.5                      | 35.2                      | 15.9                      | 34.0                      | 15.4                      | 32.8                      | 14.9                      | 31.8                      | 14.4                      |
| 1524m (5000ft)  | 35.1                      | 15.9                      | 33.9                      | 15.4                      | 32.7                      | 14.8                      | 31.6                      | 14.3                      | 30.6                      | 13.9                      |
| 1829m (6000ft)  | 33.8                      | 15.3                      | 32.6                      | 14.8                      | 31.5                      | 14.3                      | 30.5                      | 13.8                      | 29.5                      | 13.4                      |
| 2134m (7000ft)  | 32.6                      | 14.8                      | 31.4                      | 14.2                      | 30.3                      | 13.8                      | 29.3                      | 13.3                      | 28.4                      | 12.9                      |
| 2438m (8000ft)  | 31.3                      | 14.2                      | 30.2                      | 13.7                      | 29.2                      | 13.2                      | 28.2                      | 12.8                      | 27.3                      | 12.4                      |
| 2743m (9000ft)  | 30.2                      | 13.7                      | 29.1                      | 13.2                      | 28.1                      | 12.7                      | 27.2                      | 12.3                      | 26.3                      | 11.9                      |
| 3048m (10000ft) | 29.0                      | 13.2                      | 28.0                      | 12.7                      | 27.0                      | 12.3                      | 26.1                      | 11.9                      | 25.3                      | 11.5                      |

# SYSTEM DIAGRAMS

## sUAS OVERVIEW

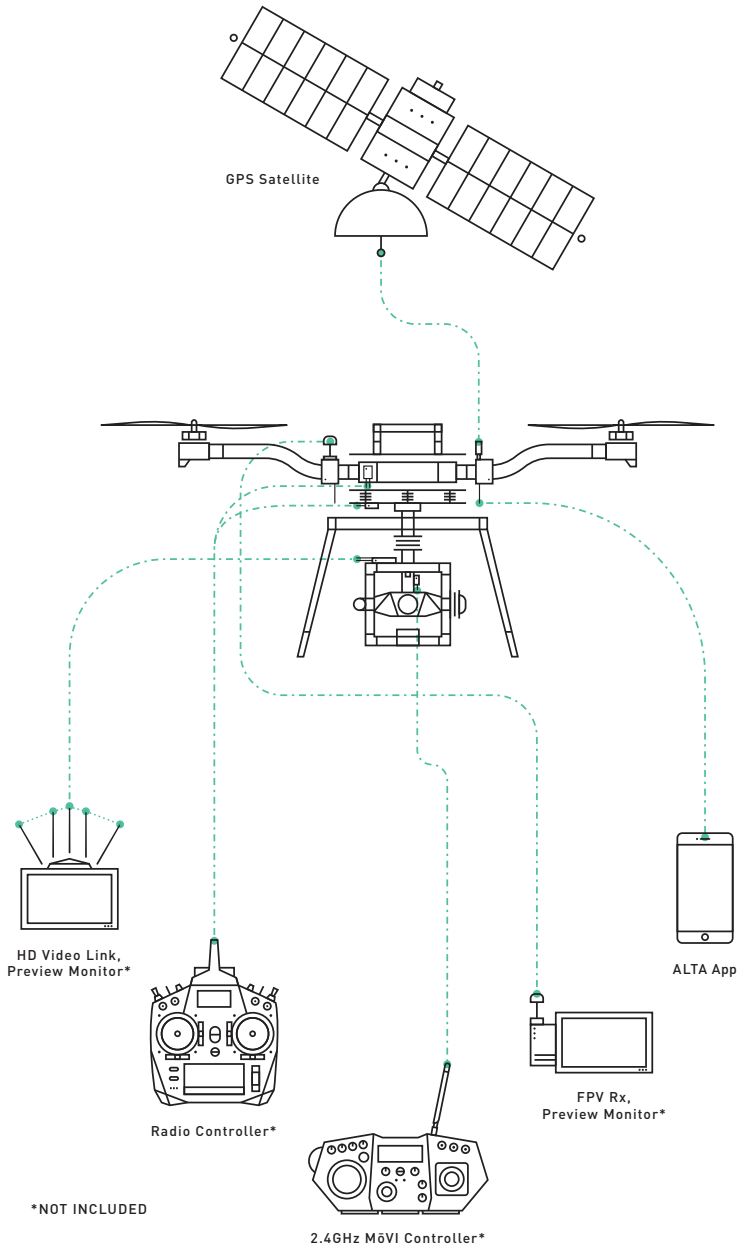

# FLIGHT CONTROL

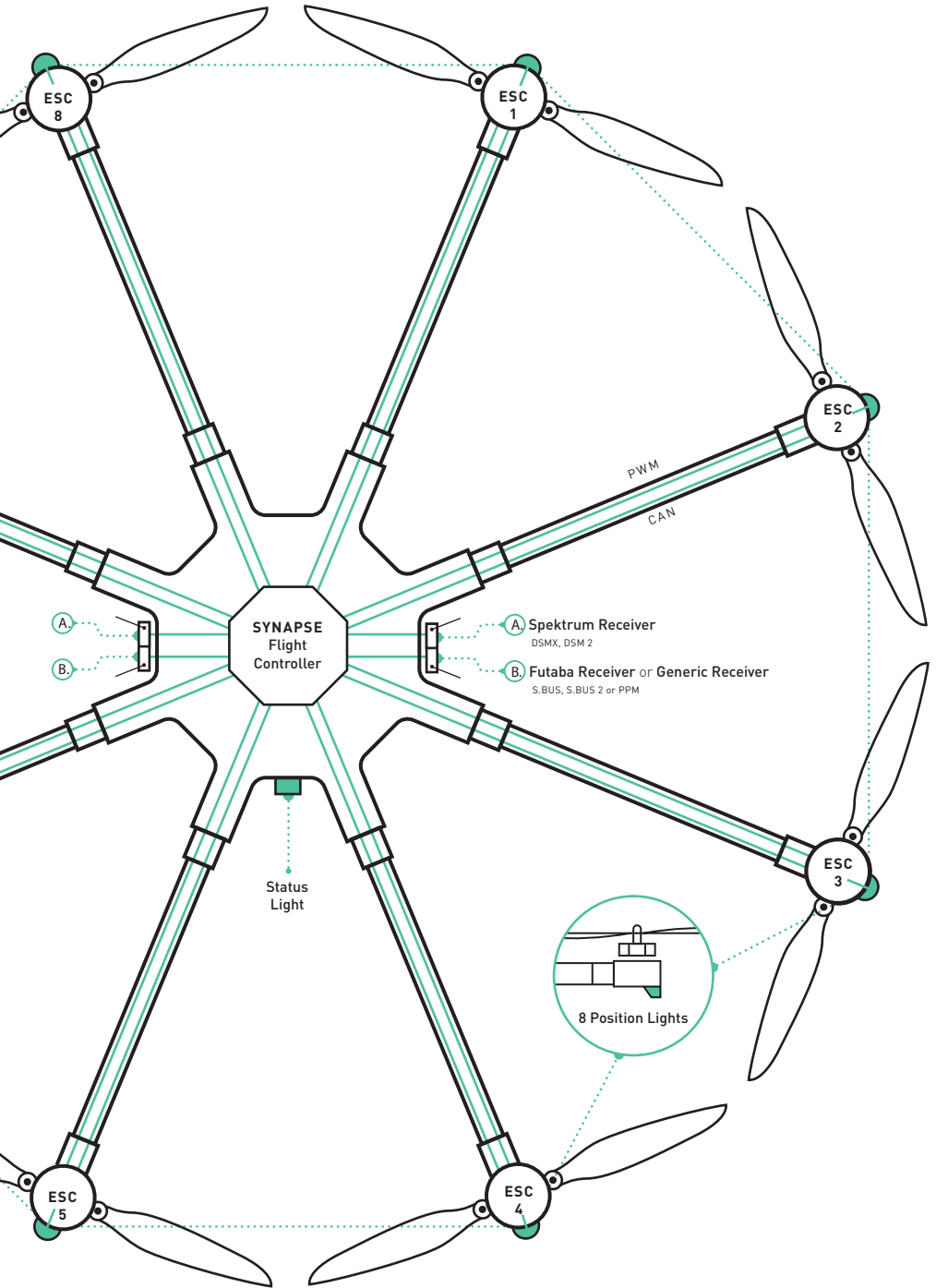

# POWER SYSTEM

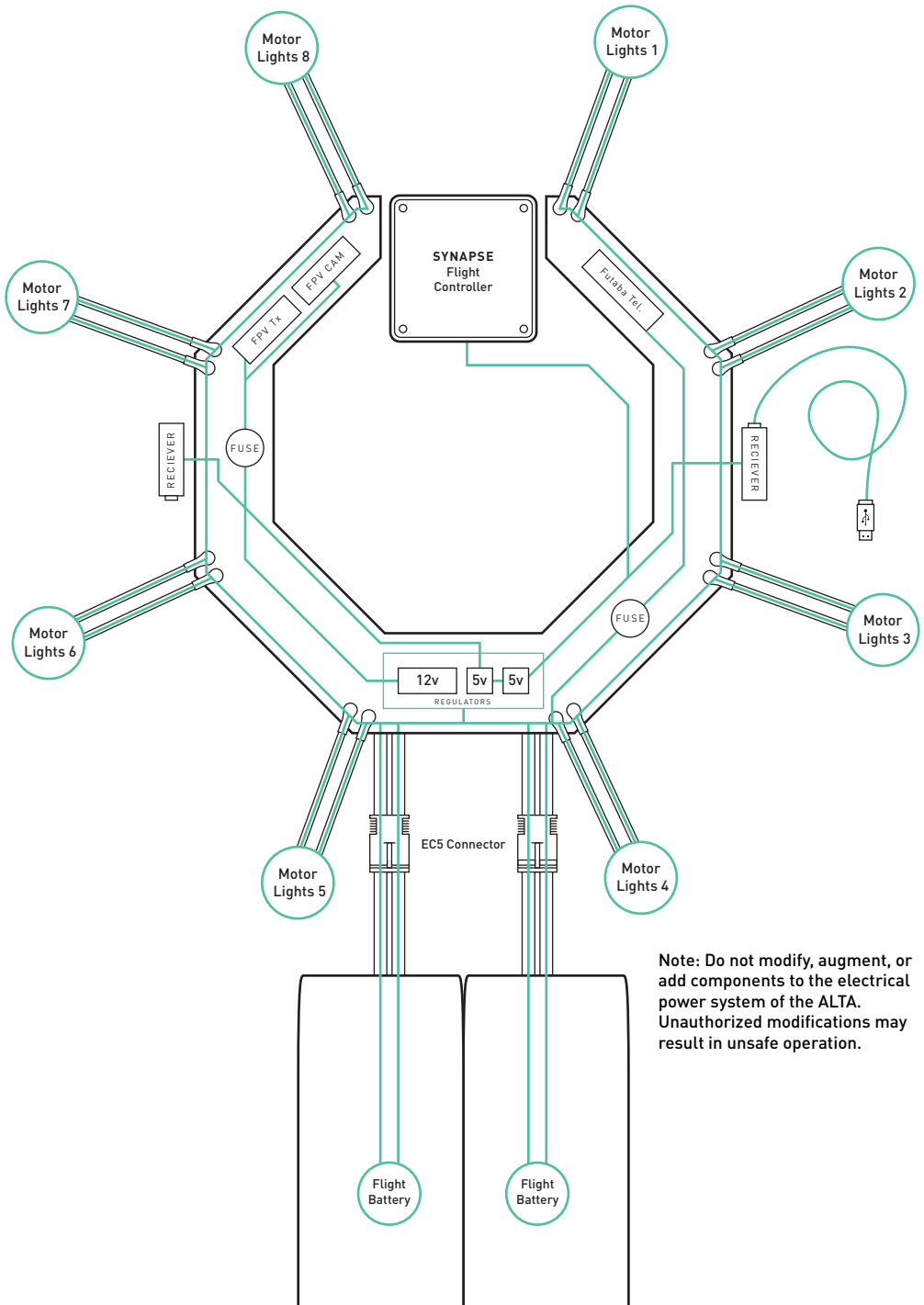

**Note:** Do not modify, augment, or add components to the electrical power system of the ALTA. Unauthorized modifications may result in unsafe operation.

# FPV EQUIPMENT

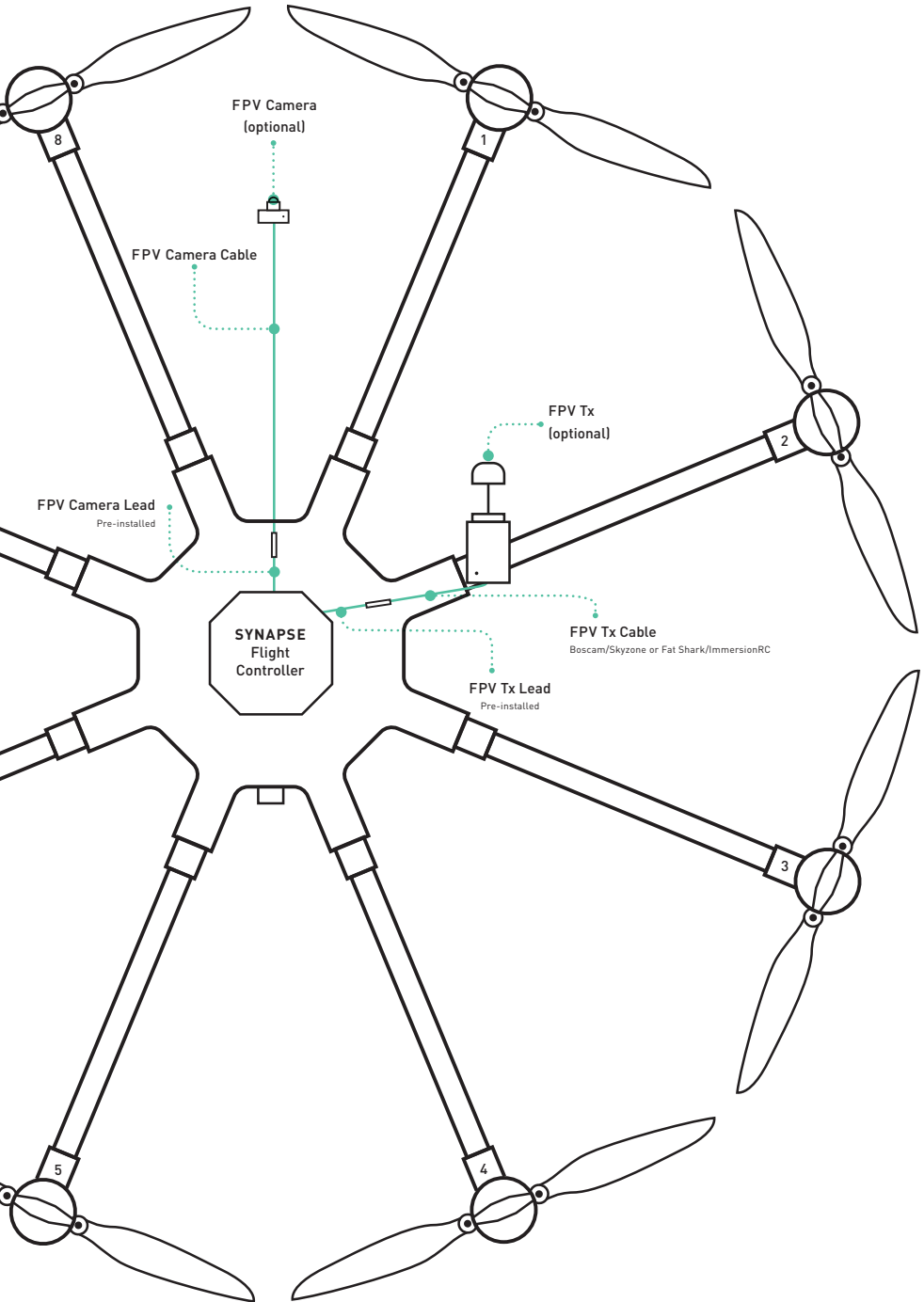

## ALTA MOBILE APP

---

The ALTA App is used to configure ALTA 8 parameters, update ALTA 8 firmware, and to monitor ALTA 8's status during flight. To download the ALTA App, search for "Freefly ALTA" in the App Store or on Google Play™.

Parameters may only be adjusted while ALTA 8 is on the ground and disarmed. In addition, radio mapping parameters can only be adjusted when the Configuration Jumper is removed. For more information on radio mapping, see the Radio Mapping section of this manual.

The ALTA App will be actively maintained, and additional functionality may be added over time. For information on individual app updates, refer to the App release notes.

### **NOTE**

---

When making configuration changes with the ALTA App, wait three seconds for the app to automatically save changes to ALTA 8 before shutting off the app or the mobile device.

---



## RADIO CONTROLLER

ALTA 8 supports a variety of radio controllers as outlined in the Flight Controller Specifications. A minimum of five (5) channels are required, with four (4) used for flight control, and the remaining one (1) used for mode selection.

However, a radio controller with at least 10 channels is highly recommended to make use of Velocity and Climb Rate Clamps, Return-to-Home (RTH), Disarm Safety, and Orbit Mode functions. It is recommended to use a radio controller with a three way switch for the Mode, Home, and Orbit functions, a two or three way switch for the disarm safety function, and a knob or slider input for both the Velocity and Climb Rate Clamp functions.

## FLIGHT BATTERY

ALTA 8 can accommodate a variety of Lithium Polymer (LiPo) flight battery packs. Battery packs must be 6S, having a nominal voltage of 22.2 V. Only run ALTA 8 using two packs at a time. Each pack must have a continuous discharge rating of 250 amps or greater, and a peak discharge rating of 500 amps or greater. For additional information on expected flight durations, refer to the Performance Section of this manual.

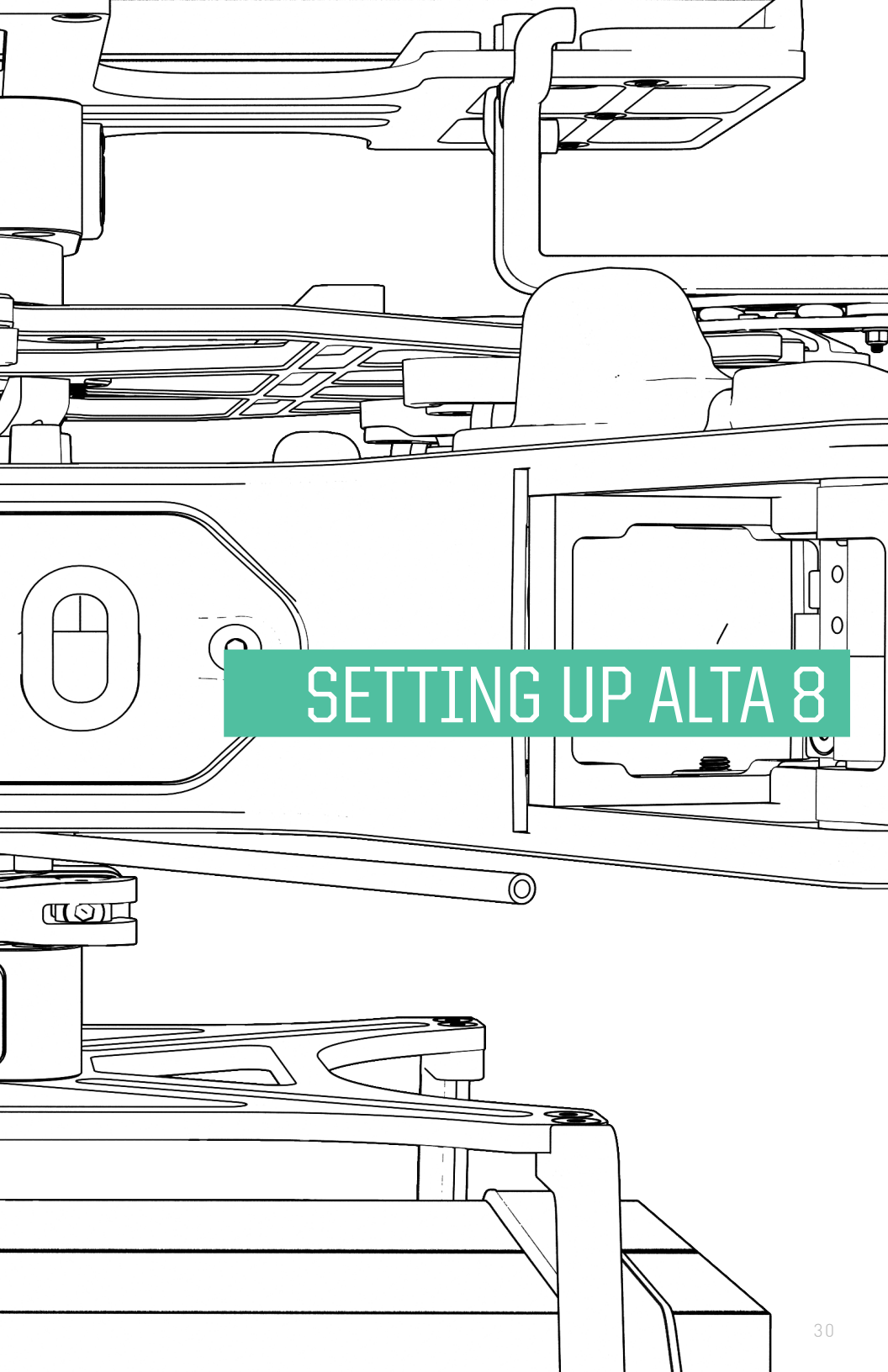

# SETTING UP ALTA 8

## UNFOLDING ALTA 8

---

ALTA 8 features swan-neck booms that fold into a compact size for travel. They are secured in an open position for flight using over-center latches.

### TO UNFOLD ALTA 8

1. Remove ALTA 8 from case
2. Fold down all eight boom retention clips

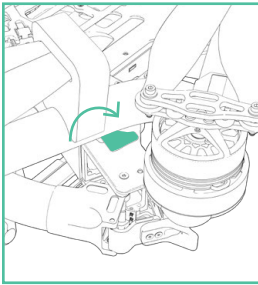

3. Open ALTA 8 booms. ALTA 8 can become unbalanced and tip over while unfolding booms individually, so unfold opposite boom pairs simultaneously to keep balance.

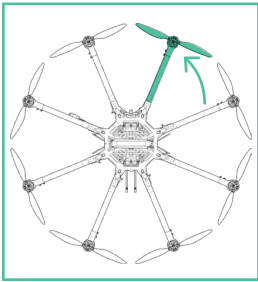

4. Snap shut all eight boom latches until they click and latch

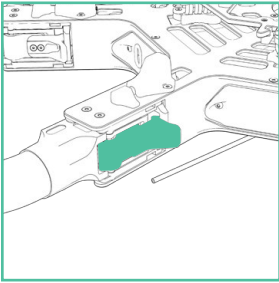

5. Visually confirm all latches are seated properly

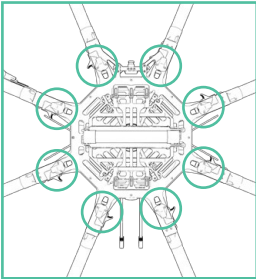

6. Remove prop protectors

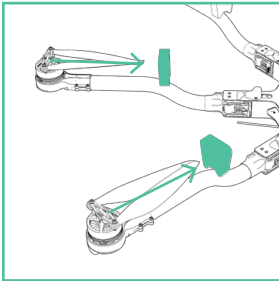

# TO FOLD ALTA 8

1. Secure props with prop protectors

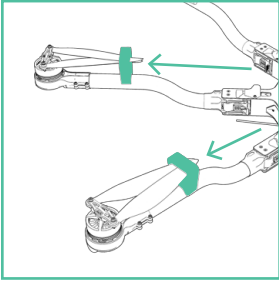

2. Unlatch all eight booms

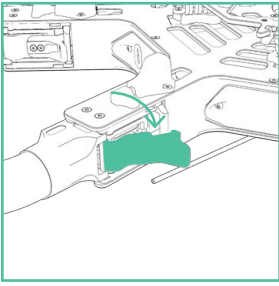

3. Close ALTA 8 booms in opposing pairs to keep balance

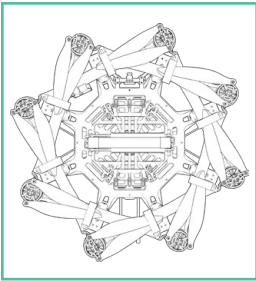

4. Fold up all eight boom retention clips to secure booms

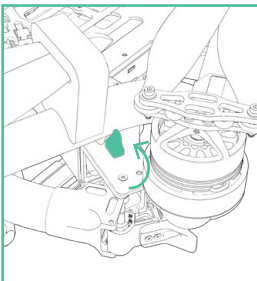

# RADIO INSTALLATION

---

## RADIO CONTROLLER RECEIVER

ALTA 8 requires the installation of a radio control system. S.Bus, S.Bus2, DSM2, DSMX, and PPM (including inverted PPM and Graupner) receiver types are supported. Some of ALTA 8 emergency control modes (Return-to-Home and Autoland) may vary depending on the type of radio. Refer to the Flight Controller Modes section of this manual for additional detail.

Additionally, ALTA 8 supports radio receiver diversity using S.Bus, S.Bus2, DSM2 and DSMX receivers. This means two receivers may be installed, and the SYNAPSE flight controller will automatically use the receiver with the best signal quality. Using two receivers requires the radio controller to be bound to both receivers.

Refer to the instructions provided with your radio controller to complete the binding process. For Spektrum/JR radios, a receiver is required to bind the satellites to a radio controller.

### FOR FUTABA AND PPM RECEIVERS

1. Locate the noted closeout panels used for receiver installation (between booms 2 & 3 and 6 & 7). PPM and Graupner receivers can only use the position between booms 2 & 3.

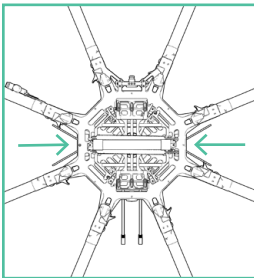

2. Remove side closeout panel with radio wires using a 2.0mm hex driver

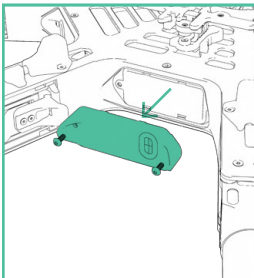

3. Plug signal wire into receiver
4. If using telemetry, plug the telemetry wire located in the closeout between booms 2 & 3 into the primary receiver (refer to the Voltage Telemetry section)
5. Feed receiver antenna into lower antenna tube

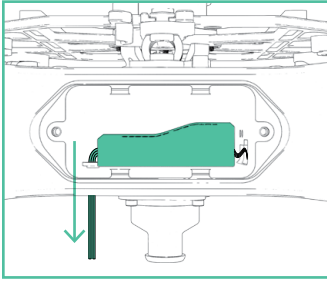

6. Secure receiver using the provided double sided tape to inside of receiver housing

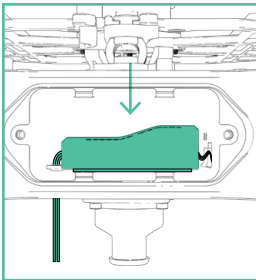

7. Reattach closeout panel

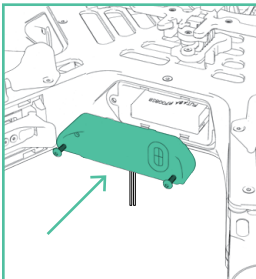

8. Route antenna wires into the two antenna tubes below ALTA 8 chassis

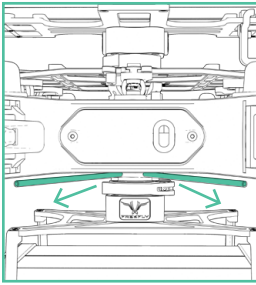

9. Repeat installation process for dual receivers (if applicable)

#### FOR SPEKTRUM/JR:

1. Locate the noted closeout panels used for Spektrum/JR receiver installation (between booms 3 & 4 and 7 & 8)

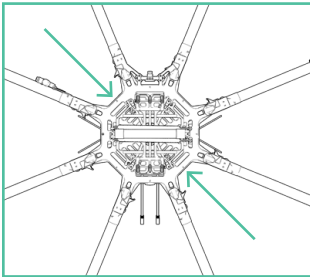

2. Remove side closeout panel using a 2.0mm hex driver

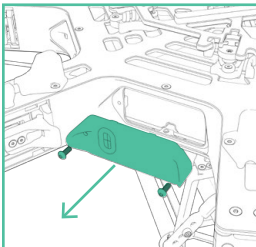

3. Feed signal cable through panel grommet

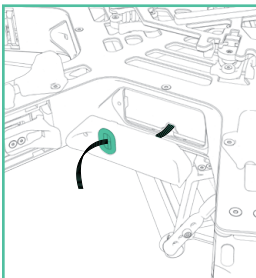



**4. Reattach closeout panel**

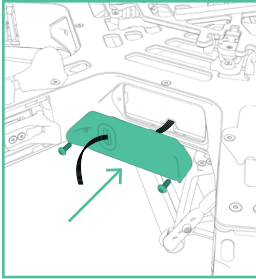

**5. Plug in receiver/satellite into signal cable**

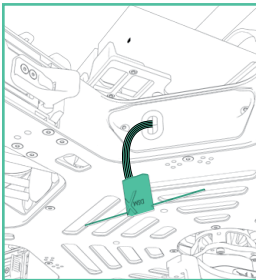

**6. Attach receiver/satellite to exterior using double sided tape**

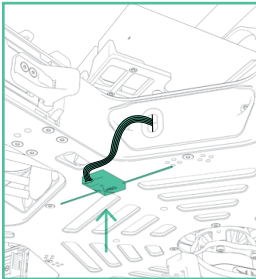

**7. Repeat steps 1-6 for dual receivers (if applicable)**

# VOLTAGE TELEMETRY

ALTA 8 supports battery voltage telemetry on Futaba radios using a receiver that supports an external voltage sensor, such as the R7008SB. Installing the telemetry wire is easiest when initially installing the receiver. To set up ALTA 8 with voltage telemetry for Futaba radios:

1. Remove the closeout panel between booms 2 and 3 with a 2.0mm hex driver and locate the radio receiver wire bundle

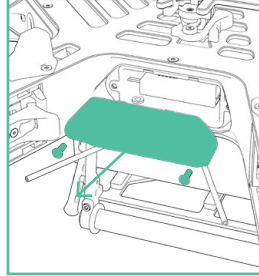
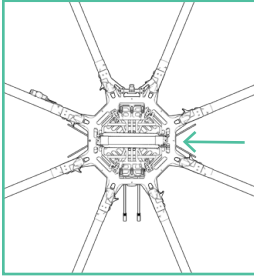

2. Identify the voltage sense wire and connector in the bundle. It is the small, 2-pin connector attached to a black and red wire pair.

## NOTE

This wire is already connected to an in-line fuse.  
Soldering a fuse into this wire is not required.

3. Connect the cable to the voltage sense port on the primary Futaba receiver

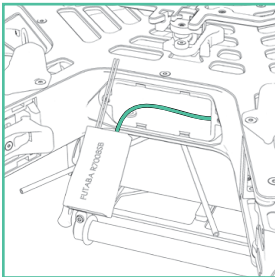

4. Reattach the closeout panel

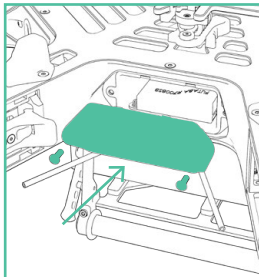

# RADIO CHANNEL MAPPING

---

ALTA 8 can be used with a variety of radio controllers. Different radio controllers can map functions to different channels, so properly mapping controller channels to ALTA 8 functions is an important step before flying. Radio channel mapping is performed using the ALTA App.

This section describes the steps required to complete radio channel mapping.

If you are uncertain about your radio channel mapping, obtain assistance from an experienced pilot or from Freefly Customer Support.

## CONFIGURATION JUMPER

A small jumper is used to prevent motor operation while configuring radio channel mapping parameters. With the jumper in place, the motors may operate, but radio channel mapping is prevented. With the jumper removed, radio channel mapping may take place, but motor operation is prevented.

To remove or replace the Configuration Jumper:

1. Locate the closeout panel between booms 5 and 6 where the jumper is installed

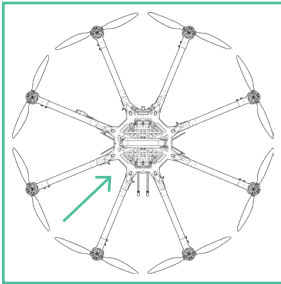

2. Remove the closeout panel using a 2.0mm hex driver

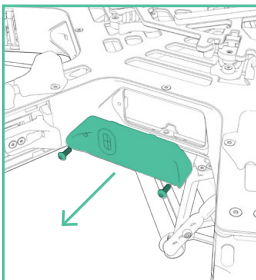

3. Remove or replace the jumper as needed

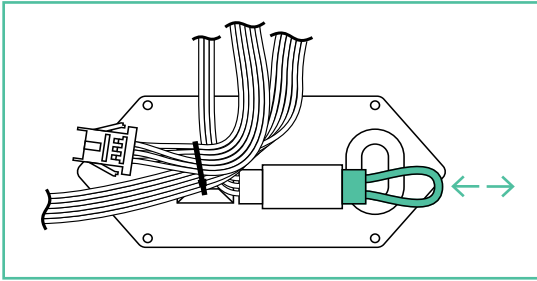

4. Reattach the closeout panel

## MAPPING RADIO CHANNELS USING ALTA APP

Radio channel mapping is accomplished with the ALTA App. Prior to mapping channels, ensure your radio controller and receivers are properly installed. Refer to the Radio Installation section of this manual and your radio controller's documentation.

1. Remove the Configuration Jumper

### **WARNING**

---

Always ensure the Configuration Jumper is removed prior to adjusting radio settings to prevent unintentional motor starts.

---

2. Power ALTA 8 using a battery pack or by plugging in the included USB-Futaba cable into an available port on a Futaba receiver
3. Open the ALTA App and connect to ALTA 8
4. Open Configurations > Radio
5. Open each ALTA 8 function and adjust the channel to the desired channel number. Use the toggle in the App to invert the control orientation as needed.
6. Ensure proper radio channel mapping by moving the control input on the radio controller and verifying the displayed graph in the ALTA App responds as-expected

### **WARNING**

---

Incorrect channel mapping can lead to immediate loss of control.

---

## ONCE CHANNELS ARE MAPPED

7. Remove the battery or USB-Futaba cable from ALTA 8
8. Replace the Configuration Jumper

## FUNCTION DESCRIPTIONS

The following functions can be mapped to radio controller channels. These are found in the Radio section of the Configurations menu in the ALTA App. Each function is also represented by a chart that responds to control input allowing for quick verification of mapping settings.

### CONTROLLER

Use this to select the appropriate receiver. The following guide is compiled for convenience. For complete specifications and which mode will work with your receiver, refer to your radio controller or receiver manuals.

- » DSM2/DSMX are typically used by Spektrum and some JR controllers.
- » SBUS is typically used by Futaba controllers.
- » PPM is a generic standard used by many controllers and receivers.
- » PPM Invert is the same as PPM except channel inputs are reversed.
- » PPM Graupner interprets Graupner radio PPM inputs.

### PITCH/ROLL/YAW/THROTTLE

The Pitch, Roll, Yaw and Throttle controls are the basic flight controls and are mapped to the two radio controller sticks.

### MODE

The required Mode Switch selects between the three different flight modes: Manual, Height, and Position. A three-position switch is recommended to select the three different modes. However, a two-position switch may be used, but will only allow for selecting between Manual Mode and (depending on radio controller mixes) either Position Mode or Height Mode

### HOME SWITCH

The optional Home Switch selects between the different Return-to-Home (RTH) functions. A three-position switch is required for the Home Switch functions to select between the Set New Home Position, RTH Off, and initiate RTH functions.

### VELOCITY AND CLIMB RATE CLAMP

Velocity and Climb Rate Clamps set the maximum ground speed or vertical speed available in Height Mode and Position Mode. The clamps can be adjusted mid-flight. An analog dial or slider is recommended for the Velocity and Climb Rate Clamp Functions.

## DISARM SAFETY

The Disarm Safety Switch aids in preventing accidental motor disarming while the ALTA is in flight and in manual mode. It may be mapped to either a two-position or three-position switch. To set up the Disarm Safety Switch, refer to the Mapping Channels section of the ALTA Aircraft Flight Manual.

## ORBIT MODE

The optional Orbit Switch selects between the different Orbit Mode functions. A three position switch is required to select between the Set Orbit Center, Orbit Off, and Orbit On functions.

## ALL FUNCTIONS

The meaning of the direction or position of the indicator is described in the following table for all mappable parameters. The top and right positions on the radio mapping indicators represent 2000 $\mu$ s, and the bottom and left positions represent 1000 $\mu$ s, and the middle position represents 1500 $\mu$ s.

| FUNCTION         | IN-APP INDICATOR POSITION | INDICATES             |
|------------------|---------------------------|-----------------------|
| Pitch            | Top                       | Nose Up               |
|                  | Bottom                    | Nose Down             |
| Roll             | Left                      | Roll Left             |
|                  | Right                     | Roll Right            |
| Yaw              | Left                      | Nose Left             |
|                  | Right                     | Nose Right            |
| Throttle         | Top                       | High Throttle         |
|                  | Bottom                    | Low Throttle          |
| Mode             | Top                       | Position              |
|                  | Middle                    | Height                |
|                  | Bottom                    | Manual                |
| Home             | Top                       | Set New Home Position |
|                  | Middle                    | RTH Off               |
|                  | Bottom                    | Initiate RTH          |
| Velocity Clamp   | Top                       | Fast                  |
|                  | Bottom                    | Slow                  |
| Climb Rate Clamp | Top                       | Fast                  |
|                  | Bottom                    | Slow                  |

|               |                 |                             |
|---------------|-----------------|-----------------------------|
| Disarm Safety | Top             | On - Disarming Not Possible |
|               | Middle & Bottom | Off - Disarming Possible    |
| Orbit         | Top             | Orbit On                    |
|               | Middle          | Orbit Off                   |
|               | Bottom          | Set Orbit Center Point      |

# TYPICAL CHANNEL MAPPINGS

The following radio channel mapping configurations are recommendations only and can be set in the ALTA App. Depending on exact radio models, these may help as an initial configuration. However, it is up to the pilot setting up ALTA 8 for flight to determine if these settings are appropriate.

## FUTABA 14SG/8FG

| FUNCTION         | CHANNEL NUMBER | DIRECTION |
|------------------|----------------|-----------|
| Pitch            | 2              | Normal    |
| Roll             | 1              | Normal    |
| Yaw              | 4              | Normal    |
| Throttle         | 3              | Reverse   |
| Mode Switch      | 5              | Normal    |
| Home Switch      | 6              | Reverse   |
| Disarm Safety    | 9              | Reverse   |
| Velocity Clamp   | 8              | Reverse   |
| Climb Rate Clamp | 7              | Reverse   |
| Orbit Switch     | 10             | Normal    |

## SPEKTRUM DX18

| FUNCTION         | CHANNEL NUMBER | DIRECTION |
|------------------|----------------|-----------|
| Pitch            | 3              | Reverse   |
| Roll             | 2              | Reverse   |
| Yaw              | 4              | Reverse   |
| Throttle         | 1              | Normal    |
| Mode Switch      | 6              | Reverse   |
| Home Switch      | 7              | Normal    |
| Disarm Safety    | 8              | Normal    |
| Velocity Clamp   | 10             | Normal    |
| Climb Rate Clamp | 9              | Normal    |
| Orbit Switch     | 5              | Normal    |



# CONFIGURING FOR MōVI

A MōVI can be attached to either the top or bottom of ALTA 8 via the Freely Toad In The Hole (TITH) quick release.

ALTA 8 comes pre-configured for GroundView mounting a MōVI.

## GROUNDVIEW

1. Prepare your MōVI for GroundView flight (see MōVI manual)
  - a. Attach landing gear
  - b. Install TITH receiver on MōVI
2. Connect MōVI to bottom Toad

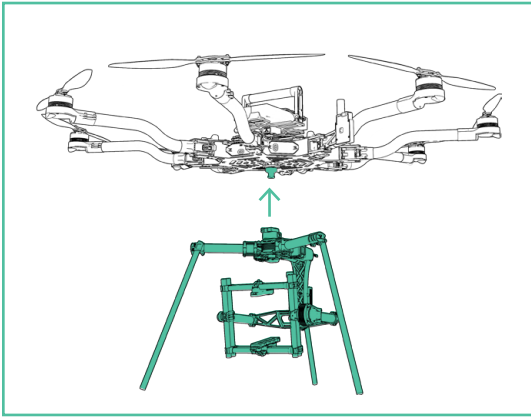

## SKYVIEW

### ⓘ CAUTION

Top mounting is not supported by the MōVI M10 without the keyed pan tube upgrade kit. If you are unsure whether your M10 has the upgrade kit, contact Freely Customer Support for additional info.

1. Prepare your MōVI for SkyView flight
  - a. Remove landing gear (see MōVI manual)
  - b. Install TITH receiver on MōVI (see MōVI manual)

2. Connect and secure the supplied inverted landing gear to the bottom Toad

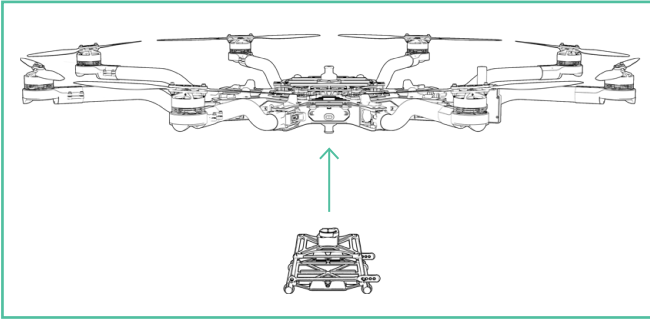

3. Remove Battery Mount Quick Release

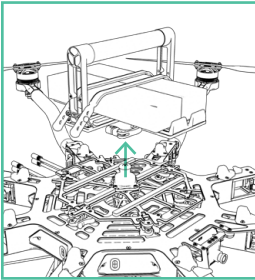

4. Connect MōVI to top Toad

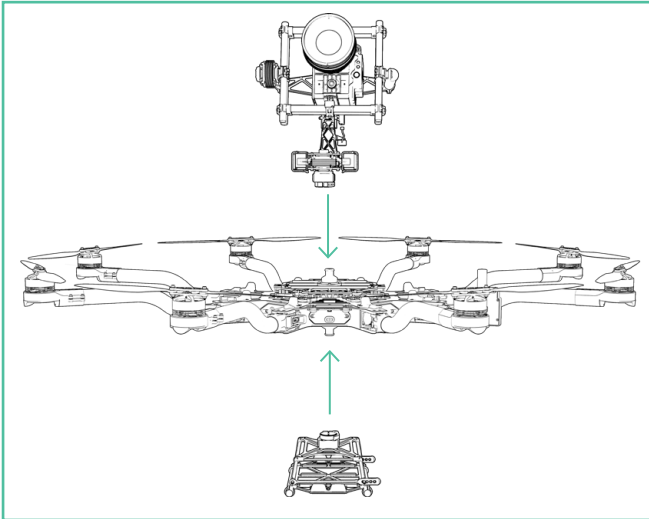

# ISOLATOR CARTRIDGES

Different Isolator Cartridges can be used to fine tune vibration damping performance for different payload weights or ambient temperatures. Three isolation cartridge styles are provided with ALTA 8. The cartridges have o-rings colored red for light payloads or cold ambient temperature, teal for medium payloads or typical ambient temperature, and black for heavy payloads or hot ambient temperature. Flight testing may be required to determine the optimal isolator for a given setup.

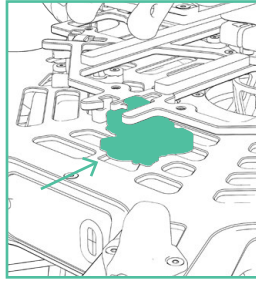
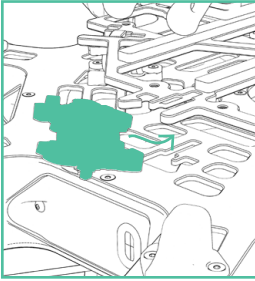

To install, place the cartridges between the top chassis plate and the battery plate. Ensure they are engaged in the track features and are parallel with the chassis and battery plate. Push inwards fully until they click, indicating the cartridges are locked in place. Pull outwards on the cartridge to ensure it is locked in place.

## ⚠ CAUTION

Always ensure isolator cartridges are locked in place before flying ALTA 8. Isolator cartridges that are not locked can cause the payload to loosen and change ALTA 8's fundamental flying characteristics.

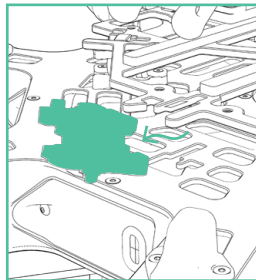
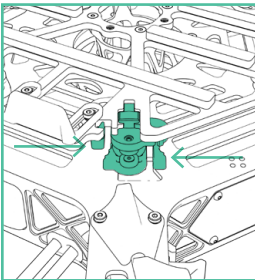

To remove, pinch the cartridge latch to unlock it from the battery and chassis plate, and slide it outwards to disengage. Simultaneously pull the battery and chassis plate apart while pulling the cartridge outward.

# BATTERY INSTALLATION

---

Batteries may be installed on either the top or bottom of an ALTA 8 and are always mounted opposite of the payload location. In both locations, battery packs are secured with silicone straps tensioned across the packs. The straps are secured using studs located on either side of the packs.

## **WARNING**

---

Always secure battery packs with both battery retention straps.

---

## **CAUTION**

---

Ensure both battery packs are at a similar state of charge (a full pack voltage difference less than 0.5V) prior to connecting them to ALTA 8. Plugging in two dissimilarly charged packs could cause one pack to rapidly discharge into the other and damage the batteries or cause a battery fire.

---

## **CAUTION**

---

Only use packs that are identical in their capacity and at a similar condition. Using a pack with another that is larger, or has many more charge/discharge cycles, can damage the battery packs.

---

## **CAUTION**

---

Always refer to and follow the battery manufacturer's instructions, recommendations and guidelines for battery handling.

---

## **CAUTION**

---

When plugging in battery packs, ensure the polarity is correct. Positive is indicated by a red power lead, and negative/ground is indicated by a black power lead. Reversing polarity will damage ALTA 8's electronics.

---

# GROUNDVIEW

1. Place battery retention strap studs at the appropriate height to hold the battery packs firmly in position

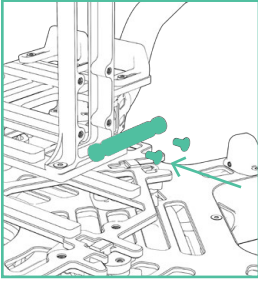

2. Adjust battery stops to fit battery packs

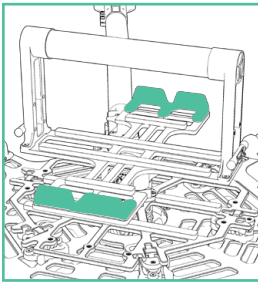

3. Attach the single-hole end of the battery retention straps to the studs

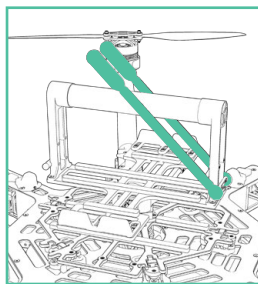

4. Place battery packs on the battery tray

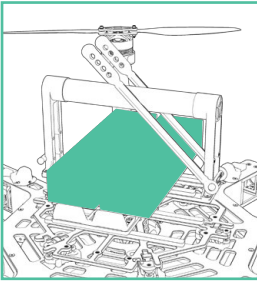

ⓘ **CAUTION**

---

Do not install batteries directly on the lower battery tray if a Toad adapter is also installed. Either remove the Toad adapter or use the Quick Release Battery Tray.

---

5. Tension and secure battery retention straps

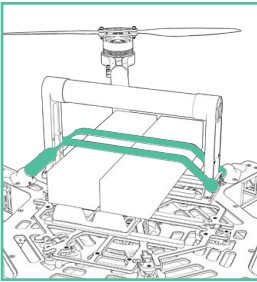

# SKYVIEW

## ⓘ CAUTION

Always completely secure the inverted landing gear by closing the TITH quick release lever. Inverted landing gear that are not completely attached can rotate and unplug battery leads.

1. Pinch the battery tray handles and slide to remove it from landing gear

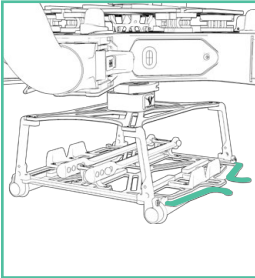

2. Attach the single-hole ends of the battery retention straps to the studs on the battery tray

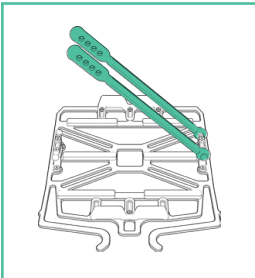

3. Place battery packs onto battery tray

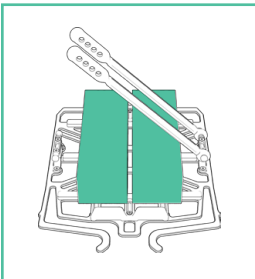

4. Tension and secure battery retention straps

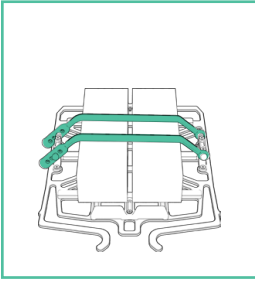

5. Slide tray with battery packs back into landing gear until the tray latches in place

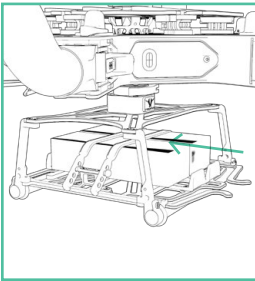

6. Ensure tray and battery packs are secure



# COMPASS CALIBRATION

---

ALTA 8 features a highly sensitive 3-axis magnetometer that measures the earth's magnetic field to infer heading. Occasionally, the compass will require calibration, especially when traveling between different geographic locations.

For best results, it is recommended to perform manual compass calibrations away from ferrous objects, buildings and vehicles. In addition, concrete can contain steel rebar which may influence compass calibrations.

## **WARNING**

---

Verify ALTA 8 is disarmed prior to performing a compass calibration. To ensure ALTA 8 does not arm, remove the Configuration Jumper, set the mode switch to Height or Position, or set the home switch to Set New Home Position.

---

## **NOTE**

---

Ensure a microSD card is installed in the GPS/compass module prior to performing compass calibration.

---

## **NOTE**

---

Perform calibration without a payload attached. It is recommended to use two people to perform the compass calibration as it requires handling and rotating ALTA 8.

---

TO PERFORM A COMPASS CALIBRATION:

1. Secure a battery onto ALTA 8
2. Plug in the battery
3. Open the ALTA App
4. Select Configurations > More > Compass
5. Under Calibration, select Start Manual
6. Perform the following steps:

1. Face North, Pitch +180°

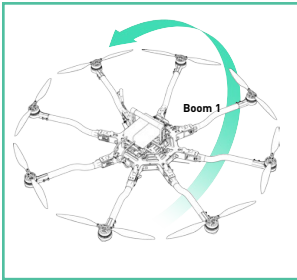

2. Pitch -360°

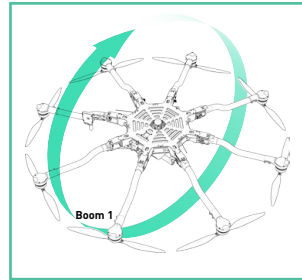

3. Pitch +180°

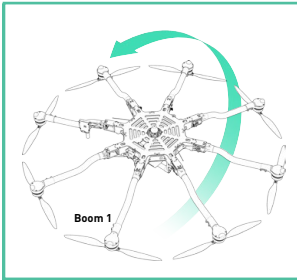

4. Face East (Yaw 90°)

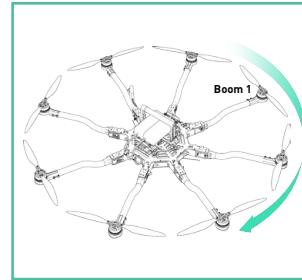

5. Roll +180°

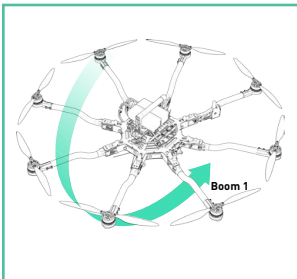

6. Roll -360°

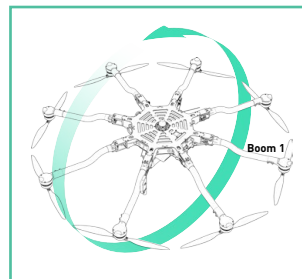

# AUTOMATIC COMPASS CALIBRATION

Automatic Compass Calibration will use compass readings over time to resolve an accurate compass calibration. Manual calibration is recommended when moving to a new location and an accurate compass calibration is needed immediately for using Position Mode.

In the ALTA App, select Configurations > More > Compass. Change the Auto Calibration setting to On.

# PROPELLERS

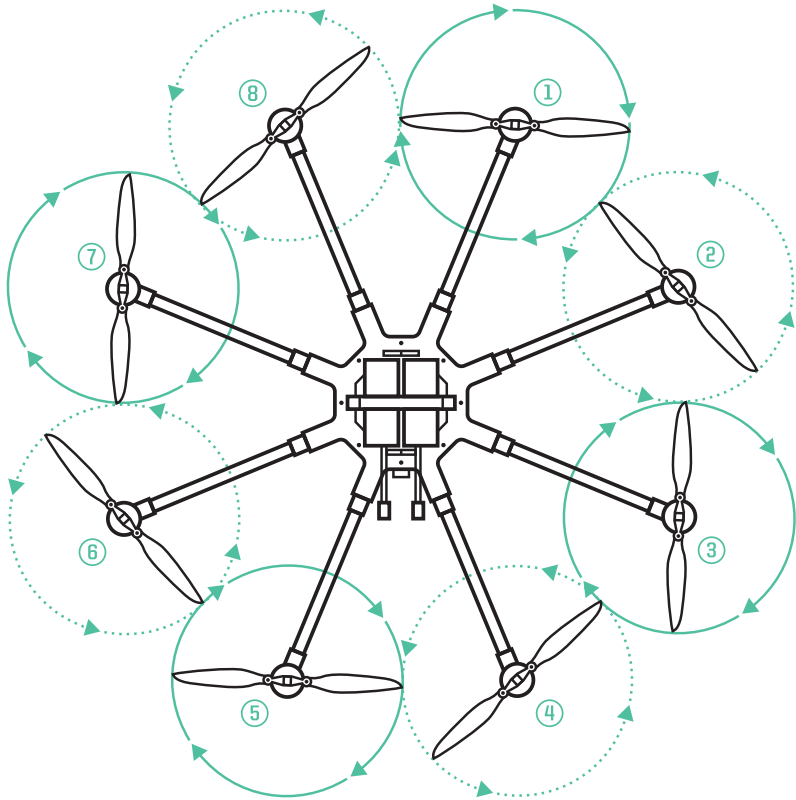

The folding propellers include two balanced carbon fiber propeller blades attached to propeller hubs, which are themselves secured to the motors. The propellers installed on booms 1, 3, 5, and 7 spin clockwise when viewed from above ALTA 8, and the propellers installed on booms 2, 4, 6, and 8 spin counterclockwise when viewed from above.

For information on propeller installation and maintenance, refer to the Maintenance section of this manual.

## ⚠ CAUTION

Only use propellers supplied by Freefly on ALTA 8. Use of third-party propellers can cause motor instability, overheating, and failure.

## CHECKING PROPELLER BOLT TIGHTNESS

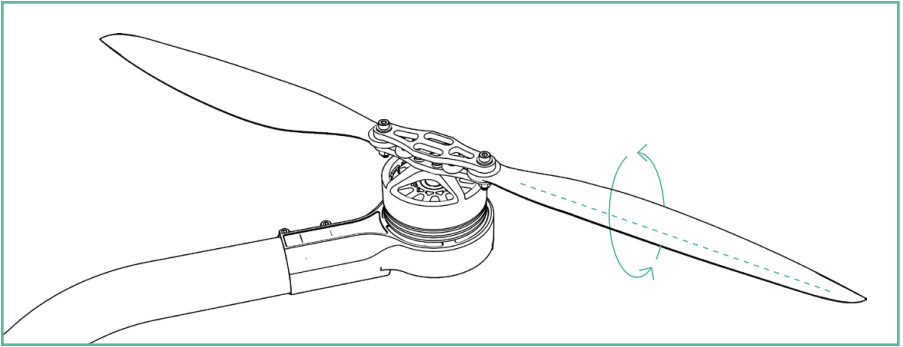

Over time, the bolts that hold the propeller blades to the propeller hub can loosen due to vibration. To check propeller bolt tightness, twist the propeller about its length. If there is free play, the propeller bolt is too loose. Use the provided 2.5mm hex driver and wrench to tighten the bolt and nut that secure the propeller blade just enough to remove the play.

### ⚠ CAUTION

---

Do not overtighten, or the propeller may fail to unfold completely during motor start up, leading to excessive vibration.

---

# FIRST PERSON VIEW (FPV)

---

ALTA 8 and SYNAPSE can power a variety of first person view (FPV) cameras and transmitters, as well as add informational on-screen display (OSD) elements to aid in FPV flying. Using an FPV ground station display can be a useful method of monitoring status, performance, and flight parameters of the ALTA 8 during flight.

Three FPV transmitter cables are included. Each supplied cable has one side with a connector that mates with a cable located in the closeout panel between booms 1 & 2. The other end of each supplied cable has specialty connector(s) to run Immersion RC, Fatshark, BOSCAM, or BOSCAM compact FPV transmitters. For cable identification, refer to the FPV Transmitter installation instructions.

A single camera cable is provided and is configured to run a Ready Made RC camera (model RMRC-700XVN recommended). This cable mates with a pre-installed cable located behind the closeout panel between booms 1 & 8.

Camera and transmitter cables follow this wiring scheme:

| CABLE COLOR | FUNCTION     |
|-------------|--------------|
| Red         | +12 VDC      |
| Black       | Ground       |
| Yellow      | Video signal |

## **WARNING**

It is the responsibility of the pilot to see and avoid other aircraft, people, or obstacles. Always maintain direct line of sight with ALTA 8 during flight, use visual observers as operations require, and follow local regulations regarding see-and-avoid requirements.

## **CAUTION**

Do not short the pins of the FPV transmitter connector located on the pre-installed FPV transmitter lead in the ALTA 8. Doing so could damage the on-screen display circuit. If using a multimeter to check the pins, first connect one of the provided transmitter cables, then take voltage readings from the transmitter cable.

# FPV SYSTEM INSTALLATION

## CAMERA

1. Remove the front closeout panel with a 2.0mm hex driver

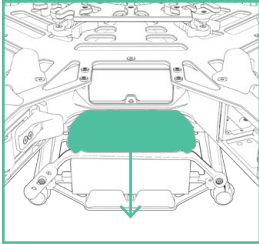

2. Locate the FPV camera cable included in the ALTA 8 package
3. Pass the FPV cable through the closeout panel grommet and connect to the mating FPV camera lead inside ALTA 8. Connect the other end directly to the camera

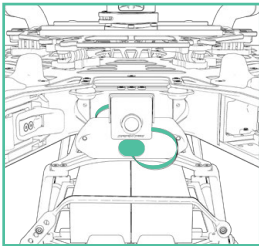

4. Replace front closeout panel.

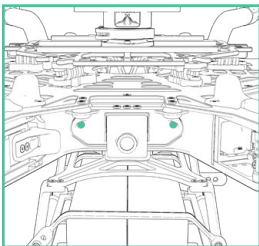

5. Mount FPV camera on the FPV mount on the front ALTA 8 using the provided hardware

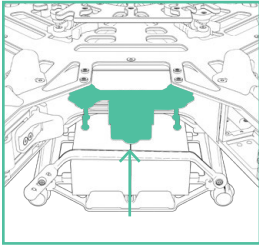

## TRANSMITTER

1. Mount FPV transmitter on the provided carbon fiber accessory mount plate

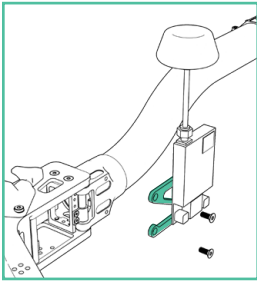

2. Attach accessory mount to boom 2 with M3x6 flathead bolts

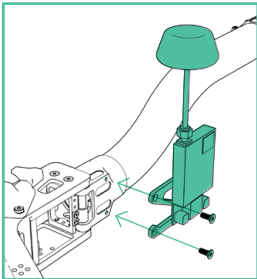

3. Locate the appropriate FPV transmitter cable. The following cables are included:

- a. ImmersionRC/Fat Shark (cable with two connectors)
- b. BOSCAM/SkyZone (cable with one large connector)
- c. Compact BOSCAM (cable with one small connector)

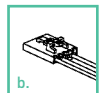



4. Remove the side closeout panel with the FPV transmitter lead between booms 1 & 2 using the 2.0mm hex driver

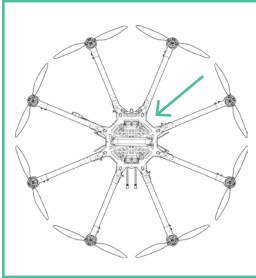

5. Pass transmitter cable through the underside of the hinge, and connect to the FPV transmitter lead

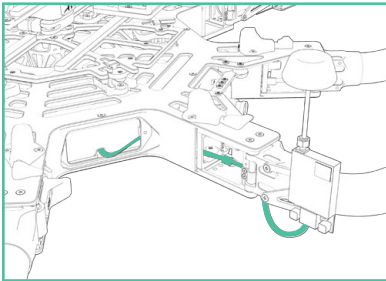

6. Replace side closeout panel

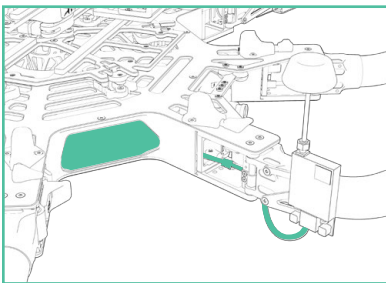

7. Zip tie the FPV transmitter lead to the boom cable bundle for strain relief

# FPV ON SCREEN DISPLAY SETUP

A number of properties and components can be adjusted or added to the FPV On Screen Display (OSD) using the ALTA App.

## PROPERTIES

| NAME              | OPTIONS           | DESCRIPTION   |
|-------------------|-------------------|---|
| Video Mode        | PAL / NTSC        | Indicates to the SYNAPSE the FPV video camera format  |
| Units             | Metric / Imperial | Changes the displayed units   |
| Horizontal Offset | 0, 15, 30, 45, 60 | Centers the OSD components horizontally   |
| Vertical Offset   | 0, 8, 16, 24, 30  | Centers the OSD components vertically   |
| Borders           | 0, 1, 2, 3        | Adds gaps between OSD components and the edges of the display, measured in character widths and heights |

## TEXT COMPONENTS

The following components are displayed as text items, and can be configured to display as big or small letters, or no letters effectively turning off the display.

| NAME         | DESCRIPTION  |
|--------------|--|
| Height       | Displays the height of ALTA 8 from its starting point in meters or feet  |
| Vario        | Displays the vertical speed of ALTA 8 in meters per second or feet per minute                                  |
| Heading      | Displays the magnetic heading of ALTA 8 and is measured in degrees   |
| Distance     | Displays the horizontal distance along the ground ALTA 8 is from the initialization position in meters or feet |
| Ground Speed | Displays the ground speed of ALTA 8 in meters per second or knots  |
| Battery      | Displays the voltage of the flight battery packs   |
| Time         | Displays the time of the flight in minutes and seconds   |
| GPS          | Displays the number of GPS satellites in view  |
| GPS Accuracy | Displays the horizontal accuracy of the GPS signal in meters or feet   |
| Lat/Long     | Displays the GPS derived latitude and longitude coordinates of ALTA 8  |

## ARTIFICIAL HORIZON COMPONENTS

The artificial horizon displays pitch and roll information in the center of the FPV display in the form of a horizon line and accompanying elements.

| NAME                   | OPTIONS        | DESCRIPTION  |
|------------------------|----------------|--|
| Artificial Horizon     | No             | Turns off all artificial horizon components  |
|                        | Basic          | Adds a horizon line that moves up and down as ALTA 8 changes pitch and rolls as ALTA 8 rolls                 |
|                        | Ladder         | Adds pitch marks at intervals defined by the Pitch Interval setting  |
| Roll Marker            | Basic          | Adds small dash marks on the left and right side of the artificial horizon that indicate changes in roll     |
|                        | Horizon        | Adds marks to include a full horizon line  |
|                        | Ladder         | Adds small marks on either side of the artificial horizon ladder that roll with ALTA 8 roll movements        |
| Pitch and Roll Scaling | 10, 20, 30, 40 | Allows for scaling of the artificial horizon markings to compensate for FPV cameras of different field views |
| Pitch and Intervals    | 10, 20, 30, 40 | Sets the number of degrees between pitch markings when the artificial horizon ladder is used                 |

## OTHER COMPONENTS

The following components can be turned on or off. These components do not have adjustable settings.

| NAME             | DESCRIPTION   |
|------------------|---|
| Compass Arrow    | Displays an arrow that points in the direction of north   |
| Home Arrow       | Displays an arrow that points in the direction of the initialization point  |
| Vario Bar        | Displays a bar on the right of the screen that scales with vertical speed. The bar will increase in length up to indicate a climb, or down to indicate a descent                                  |
| Forward Velocity | Displays a bar on the left of the screen that scales with the forward/rearward velocity component<br>The bar will extend up to indicate forward velocity, or down to indicate a rearward velocity |

Sideslip

Displays a bar on the bottom of the screen that scales with the side-to-side velocity component

The bar will extend left to indicate leftward velocity, or right to indicate rightward velocity

# TUNING ALTA 8

---

ALTA 8 comes pre-tuned for a wide variety of payloads and flying conditions. Generally, additional tuning is not required to fly ALTA 8, and additional tuning will only need to take place if more customization of control feel is desired. Default tuning values are included in Appendix A, Default Tuning Values.

Parameters fall into three categories - Attitude, Height, and Position. Typically, tuning should take place in that order, ensuring Attitude parameters are set first, then moving to Height parameters, and finally Position parameters.

Before tuning, the user should read and become familiar with all flight controller modes listed in the Operating ALTA section of this manual. Tuning should take place as an iterative process by making only small changes, test flying the changes, observing the new flight behaviors, and repeating. Only tune a single parameter at a time during this process for best results.

To tune ALTA 8, open the ALTA App and select Configurations > Aircraft Dynamics.

## **WARNING**

---

Tuning can change the fundamental flying characteristics of ALTA 8. It is possible for ALTA 8 to become unstable or even uncontrollable if values are set too high or too low. Only change tuning parameters in small increments and with caution. Always test new tuning configurations in open areas away from people or obstacles.

---

## **NOTE**

---

The ALTA App only allows tuning while ALTA 8 is on the ground.

---

## **NOTE**

---

When making configuration changes with the ALTA App, wait three seconds before closing the app for changes to be saved automatically.

---

# ATTITUDE TUNING

Attitude tuning adjusts how ALTA 8 responds to control inputs and disturbances. Attitude directly controls responsiveness and changes ALTA 8's fundamental flying behaviors. Attitude must be tuned acceptably before tuning height or position parameters.

When tuning attitude, the primary parameter to change is Stiffness followed by Strength.

## STIFFNESS

Stiffness is adjusted for pitch and roll simultaneously, and yaw independently. It changes how stable ALTA 8 is in these axes and is the primary variable to adjust when tuning. When tuning Stiffness first, or making large stiffness changes, Hold Strength should be set to a low, non-zero value.

Higher Stiffness values give more responsive control. Values that are too high can cause instability or oscillation.

### **WARNING**

---

Excessively high stiffness values can cause ALTA 8 to become unstable and difficult or even impossible to control.

Lower Stiffness values give less responsive control. Values that are too low can cause a vague or disconnected control response.

---

## HOLD STRENGTH

Hold Strength controls how much ALTA 8 will try to maintain a pitch/roll angle command, or a yaw heading command. It is adjusted for pitch and roll simultaneously, and yaw independently. A higher Hold Strength setting will give a faster control response and a more responsive feel. However, values that are too high can cause ALTA 8 to overshoot pitch or roll commands, or even cause instability.

### **WARNING**

---

Excessively high strength values case cause ALTA 8 to become unstable and difficult or even impossible to control.

Typically, this setting will not need to be changed from the default value, and only then in small increments.

---

## HEIGHT TUNING

Tuning height parameters will adjust the control feel of ALTA 8's height control while in Height and Position modes (for additional information on flight modes, see the Flight Controller Modes section of this manual). Tune height parameters only after satisfactorily tuning attitude parameters.

Similar to attitude tuning, stiffness is the primary tuning parameter.

If switching to Height Mode causes ALTA 8 to fly in an unstable manner, switch back to Manual Mode, land, and try reducing the values of height tuning gains if they are very high or increasing them if they are very low.

### VERTICAL STIFFNESS

Vertical Stiffness Gain modifies the vertical stability of the ALTA 8 in Height mode. Decrease this value if ALTA 8 experiences vertical oscillation or vibration. Increase this value if ALTA 8 is sluggish while accelerating to a desired climb or descent rate in Height mode.

### HOLD STRENGTH

Hold Strength Gain tunes how much ALTA 8 will attempt to stay on a desired altitude in Height Hold mode only. A higher value will result in height being held more precisely. A value too high can cause ALTA 8 to overreact to winds, gusts, or turbulent air.

### CLIMB RATE STRENGTH

Climb Rate Strength adjusts how much ALTA 8 will attempt to maintain a desired climb rate. Higher values will result in a more direct feel between pilot climb or descent commands and ALTA 8 flying behavior. However, values that are too high may cause instability.

## POSITION TUNING

Tuning position parameters will adjust how well ALTA 8 maintains a desired ground speed or a position over the ground. Similar to attitude and height tuning, the primary value to adjust is stiffness.

### HORIZONTAL STIFFNESS

This changes the horizontal stability of ALTA 8. Higher values increase ALTA 8's resistance to wind gusts or turbulence from moving ALTA 8 off its target position. Values that are too high can cause instability of ALTA 8.

## **HOLD STRENGTH**

This adjusts how much ALTA 8 will attempt to maintain its place over a target position. A higher value will result in position being held more precisely. If too high, positional instability can result, causing ALTA 8 to fly past a target position.

## **KINEMATIC MODE**

When selected, Kinematic mode affects the control feel of the ALTA 8 in Position Mode only. This control algorithm uses inertial and friction models to control the ALTA 8 response to stick inputs. Kinematic Mode is intended to make the ALTA 8 flight characteristics feel more like Manual Mode control while still benefiting the user with GPS assist.

## **KINEMATIC MASS**

This is the primary tuning parameter to adjust the feel of the ALTA 8 when Kinematic Mode is enabled. Tuning Kinematic Mass to higher values makes the ALTA behave as an object with more inertia; it will glide to a stop over a further distance when decelerating or take longer to gather speed when starting a pass. Tuning Kinematic Mass to lower values will make the ALTA 8 snappier and accelerate at higher rates when starting or stopping flight passes.



# ALTA 8 FLIGHT PARAMETERS

---

Flight Parameters are different from tuning parameters in that the flight characteristics of ALTA 8 will not change with their modification. However, they can be used to select neutral points using trim, or to set maximum or minimum values.

## ATTITUDE

### PITCH AND ROLL TRIM

Use Pitch and Roll trim settings to correct for tendencies of the ALTA 8 to pitch or roll with a neutral control input.

Use the in-app pitch and roll trim settings instead of radio controller trim features as large radio controller trims could prevent position hold from engaging at neutral stick positions.

### MAXIMUM PITCH/ROLL ANGLE

This sets the maximum angle ALTA 8 will be allowed to fly in any flight modes and in all flight conditions.

### MAXIMUM YAW RATE

This is the maximum rate ALTA 8 will yaw (pan) when at full stick deflection.

## HEIGHT

### HOVER THROTTLE

Hover Throttle is a parameter that adjusts ALTA 8's thrust at center throttle stick and ensures ALTA 8 does not climb or descend at the center stick position while flying in Manual Mode. A Hover Throttle setting that is too high or too low can cause ALTA 8 to climb or descend when switching between Manual and Height Mode.

#### **NOTE**

---

Hover Throttle will need to be adjusted when changing the overall weight of the system or when moving between very different elevations.

---

Increase Hover Throttle if the throttle stick must be set above center in order to hover in Manual Mode, and decrease Hover Throttle if the throttle stick must be set below center in order to hover in Manual Mode.

Alternatively, if ALTA 8 climbs when switching from Manual to Height mode, increase hover throttle since a climb indicates a stick position that is higher than neutral in Manual Mode. If ALTA 8 descends, decrease hover throttle since a descent indicates a stick position that is lower than neutral in Manual mode.

### **NOTE**

---

The ALTA App does not allow real-time hover throttle adjustments while ALTA 8 is flying. Therefore, adjust the hover throttle while the ALTA 8 is on the ground, and test fly to assess the result.

---

## **MAXIMUM CLIMB RATE**

This sets the maximum speed ALTA 8 will climb at full throttle stick deflection in Height Mode or Position Mode.

If Climb Rate Clamp is mapped to a radio controller channel, the parameter will adjust the fastest climb speed available to the Climb Rate Clamp feature.

## **POSITION**

### **MAXIMUM G**

This sets the total maximum acceleration, in G's, that the controller will place on the airframe. It is recommended to use lower G settings with heavier payloads.

This setting has no effect in Manual Mode.

### **MAXIMUM GPS ANGLE**

This sets the maximum pitch and roll angle the ALTA 8 may fly under Position mode. This will not override the Attitude Maximum Pitch/Roll Angle. Instead, ALTA 8 will follow the lower of these two limits when flying in Position Mode.

### **MAXIMUM GPS SPEED**

Max GPS Speed sets the maximum ground speed ALTA 8 will fly at full stick deflection in Position Mode.

If Velocity Clamp is mapped to an RC transmitter channel, the parameter will adjust the fastest ground speed available to the Velocity Clamp feature.

# SAFETY

## ALARM VOLTAGE

This adjusts the per-cell voltage warning level. Below this value, the Status Light will illuminate red and Orientation Lights will flash, indicating the flight packs are at a low state of charge.

## LAND VOLTAGE

This adjusts the per-cell voltage limit below which ALTA 8 will begin to Autoland while flying in Height or Position Mode. Below this value, the Status Light and Orientation Lights will flash to convey the flight packs are at or below the land voltage. When flying in Manual Mode, the pilot will be alerted by the alarm indication, but Autoland will not be initiated.

## SAFE HEIGHT

This adjusts the minimum height above the starting point at which ALTA 8 will fly during a Return-to-Home.

## AUTOLAND DESCENT RATE

This adjusts the descent rate of the ALTA 8 during Autoland in meters per second. This value is applied to the Autoland descent profile for the final 15 meters above the ground until landing. The Autoland descent profile is hard-coded and adjusts automatically as a function of height when the ALTA 8 is above 15 meters.

## RTH SPEED

This adjusts the ground speed at which ALTA 8 will fly during a Return-to-Home.

## SIGNAL LOS ACTION

This parameter determines the flight mode ALTA 8 will enter if it detects a Loss-of-Signal (LOS). Selecting 'LAND' will cause ALTA 8 to Autoland in place when the LOS is detected. Selecting 'RTH' will cause ALTA 8 to Return-to-Home and then Autoland when the LOS is detected.

### **NOTE**

---

Signal LOS Action functionality may be limited when using receiver types other than S.Bus/S.Bus2 or DSM2/DSMX. Refer to the Flight Controller Modes section of this manual for additional information.

---

## MOTION BOOTING

Motion Booting can be used when powering up ALTA 8 from a moving platform such as a boat. Motion Booting bypasses sensor checks during boot, so it should remain off whenever possible.

## CEILING

This adjusts the highest altitude the ALTA 8 is allowed to climb from its starting point while in Height or Position modes. If the maximum ceiling is exceeded in Manual mode, the Status Light will illuminate white.

### NOTE

---

The maximum ceiling parameter can be turned off in the ALTA App, and the maximum height of the ALTA 8 will be unconstrained in all flight modes.

---

## RANGE

Range sets the maximum distance ALTA 8 may fly away from the home point while in Position mode. If the range is exceeded in Manual mode, the Status Light will illuminate white.

### NOTE

---

The maximum range parameter can be turned off in the ALTA App, and the maximum flight distance of the ALTA 8 will be unconstrained in all flight modes.

---

# RESETTING ALTA 8 WIFI PASSWORD

If you forget your WiFi password and are locked out, you can reset it with the steps below. It will also reset your SSID (if you have renamed your device).

## ALTA

1. Power on.
2. Within 3 seconds of powering on, press and hold the reset button\* for 10 seconds.
3. Power cycle.

\*Reset button is located on the front of the GPS unit. On ALTA 6, the GPS unit is located on Boom #2. On ALTA 8, the GPS unit is located on Boom #7.

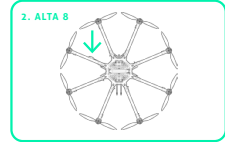
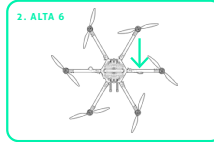

## MōVI M10/M15 - WiFi Edition

1. Power on.
2. Within 3 seconds of powering on, press and hold the reset button\* for 10 seconds.
3. Power cycle.

\*Reset button (orange) is located on the front face of the GCU enclosure.

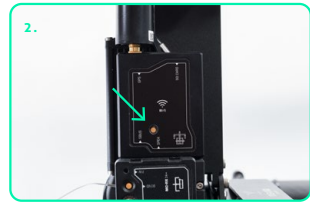

## MōVI WiFi Adapter

1. Press and hold the reset button.
2. Power on and keep the reset button held for 10 seconds.
3. Power cycle.

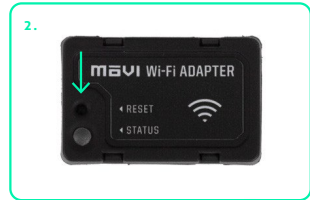

## MIMIC Beta - WiFi Edition

1. Power on and wait until boot is complete.
2. Quickly press the Pan Freeze Button 8 times.
3. Power cycle

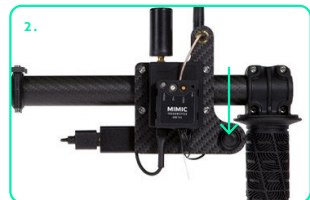

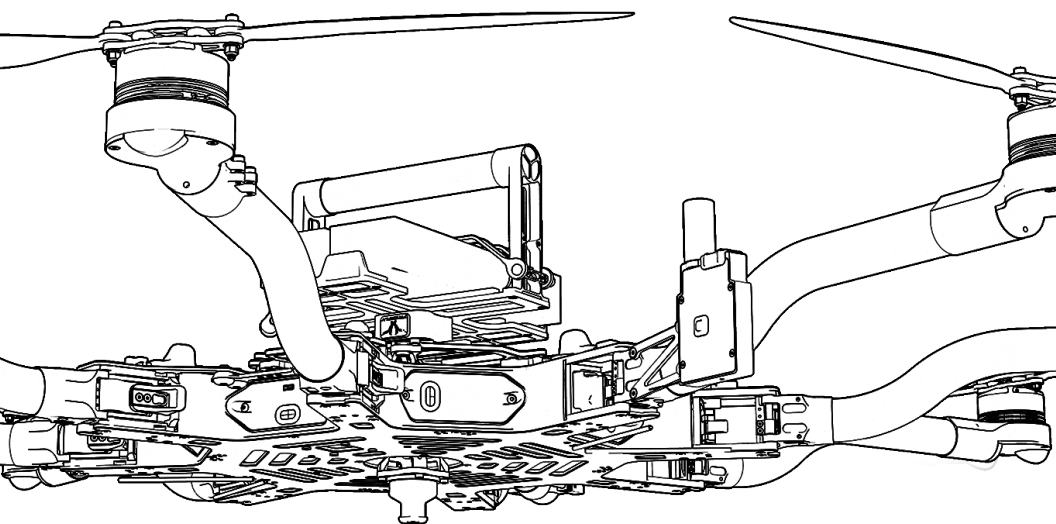

# OPERATING ALTA 8

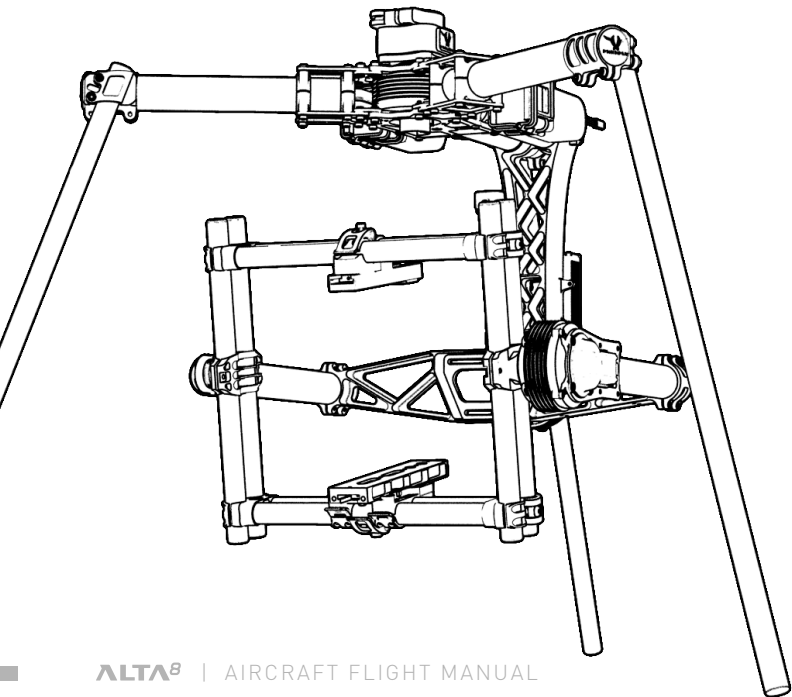

## OPERATING ALTA 8

ALTA 8 has three primary flight control modes which are selected using the Mode Switch: Manual Mode, Height Mode, and Position Mode. Position Mode includes two control styles that can be selected in the ALTA App per user preference (Classic and Kinematic). ALTA 8 has an assistive Orbit Mode which is available when Position Mode is active. ALTA 8 also has two emergency control modes, Return-to-Home and Autoland, which are available only during certain situations. For additional information, refer to the sub-section associated with each emergency control mode.

### **WARNING**

---

Height Mode and Position Mode are assistive only and are not a replacement for pilot skill and ability. Pilots should be proficient in Manual Mode flight in order to react to emergency situations as required.

---

### **CAUTION**

---

Always center the control input sticks on the radio controller when switching between control modes to prevent unexpected movement of the ALTA 8.

---

## MANUAL MODE

In Manual Mode, ALTA 8 will only stabilize its attitude. At neutral control input (middle pitch and roll stick position), ALTA 8 will attempt to remain level. Throttle control is direct.

## HEIGHT MODE

Height Mode changes the throttle stick behavior to command climb and descent rates. The higher the throttle stick position, the faster ALTA 8 will climb. Conversely, the lower the throttle stick position, the faster ALTA 8 will descend.

When the throttle stick is centered, ALTA 8 will enter Height Hold. In Height Hold, ALTA 8 will maintain a target altitude and try to correct for drift. If a disturbance moves ALTA 8 away from this target altitude, ALTA 8 will climb or descend to return to the target altitude.

### **WARNING**

---

Height Mode is assistive only and is not a replacement for pilot skill and ability. Pilots should be proficient in Manual Mode flight in order to react to emergency situations as required.

---

## POSITION MODE

Position Mode changes the pitch/roll stick behavior to command ground speeds. Pitch and roll stick deflection will command fore/aft and left/right ground speeds respectively. Controlling altitude in Position Mode is the same as in Height Mode.

With pitch and roll controls centered, ALTA 8 will enter Position Hold. In Position Hold, ALTA 8 will maintain its position over a given point on the ground and correct for disturbances.

Position Mode requires a strong GPS signal and communication with a minimum of 6 satellites. If a weak signal is present, ALTA 8 will not enter Position Mode. If the GPS signal degrades while in Position Mode, ALTA 8 will automatically revert to Manual Mode.

Within Position Mode, the user can select between two control styles. The Classic controls use the Horizontal Stiffness and Hold Strength parameters to control translational position over the ground. Kinematic Mode uses inertial and friction models to control the ALTA 8 response to stick inputs.

### **WARNING**

---

Position Mode is assistive only and is not a replacement for pilot skill and ability. Pilots should be proficient in Manual Mode flight in order to react to emergency situations as required.

---



## **WARNING**

---

Flight using Position Mode in areas of degraded GPS signal, such as near buildings or under dense tree cover, is not recommended. The automatic reversion to Manual Mode can cause unexpected, abrupt changes in flight behavior.

---

## **WARNING**

---

Flight using Position Mode with Compass enabled in areas near large ferrous objects or high magnetic flux is not recommended. Incorrect compass readings can result in loss of control. Compass assist can be disabled in the ALTA App if desired.

---

## ORBIT MODE

Orbit Mode allows the pilot to perform circular orbits of a desired radius around a manually-set center point. Position Mode must first be active in order to enter Orbit Mode. When activated, Orbit Mode constrains the radius and automatically yaws ALTA 8 to point towards the center point as the pilot uses roll left or roll right commands to traverse the flight path. The pilot maintains throttle control in order to ascend or descend as desired. The radius of the circular orbit can be adjusted real-time using pitch forward or pitch backward commands.

## RETURN-TO-HOME

Return-to-Home Mode will command ALTA 8 to fly back to the starting point of the flight or the last defined Home Point. When ALTA 8 first acquires a GPS position, it sets this as the Home Point of the flight. The Home Switch on your radio controller can be used to set a new Home Point within 20 meters of the initialization point. See the Radio Channel Mapping section in this manual for more information on setting up the Home Switch.

RTH can be initiated automatically with an LOS event if it is selected as the Signal Loss Action in the ALTA App. RTH can also be initiated manually while flying in Position Mode and setting the Home Switch to RTH.

## NOTE

Full functionality of the SYNAPSE LOS features is only available on an S.Bus/S.Bus2 or DSM2/DSMX receiver. PPM receivers must be programmed with failsafe actions manually before flight.

When initiated manually using the Home Switch, ALTA 8 will fly back to the Home Point, and the pilot will maintain control of ALTA 8's altitude the entire time. ALTA 8 will hover above the home point and wait for further commands. The pilot can cancel the RTH procedure by commanding a pitch or roll command or by retuning the Home Switch to the middle position. The Mode Switch must first be in Position Mode to activate RTH manually.

During an LOS event, RTH followed by Autoland will be initiated automatically if 'RTH' is selected as Signal Loss Action in the ALTA App and an S.Bus/S.Bus2 or DSM2/DSMX radio system is in use. ALTA 8 will first check its current altitude against Safe Height. If ALTA 8 is below the Safe Height, it will climb to Safe Height. If ALTA 8 is above Safe Height, it will remain at its current altitude. Next, ALTA 8 will fly back to the home position at the RTH Speed set in the ALTA 8 App. Finally, upon reaching the home position, ALTA 8 will begin Autoland.



## NOTE

When using a PPM receiver, the pilot must program the receiver with the desired LOS action prior to flight. Typically, the receiver can be programmed to set ALTA 8 to Position Mode and command RTH in the event of LOS, and ALTA 8 will follow the RTH function as if it is a manually-initiated RTH.

# AUTOLAND

The Autoland function will command ALTA 8 to hover for 10 seconds and will then land in place. The vertical speed at which the ALTA will descend during an Autoland varies as the ALTA approaches the ground. Higher above the elevation of the home point, ALTA 8 descends at faster rate and gradually slows to the user-defined Autoland Descent Rate before landing. The descent profile is defined as follows:

- » >45m (148ft): ALTA 8 descends at 8m/s (26ft/s)
- » 15 to 35m (49 to 115 ft): ALTA 8 descends at 3 m/s (10 ft/s)
- » <15m to ground (49 ft): ALTA 8 descends at the Autoland Descent Rate defined by the pilot until touchdown

Autoland will only initiate if one of the following conditions is met:

- » Loss of Signal (LOS) occurs and 'Land' is selected as the Signal Loss Action in the ALTA app
- » At the end of a LOS Return-to-Home event when using S.Bus/S.Bus2 or DSM2/DSMX radio systems
- » Battery exhaustion while flying in Height or Position modes only

## **WARNING**

---

Battery exhaustion will not result in Autoland while flying in Manual Mode. Full control authority is given to the pilot.

---

# HOME SWITCH

---

The home switch has three settings: Set Home, RTH Off and RTH On.

## SET HOME

Set Home sets a new home point at ALTA 8's current position. This could be useful for setting a point away from the initialization point, such as if the ALTA 8 was started underneath an overhang or a tree.

A new home point can only be set within 20 meters of ALTA 8's starting point. Momentarily moving the Home Switch to the Set Home position sets a new home point. When a new home point is set, the Status Light will turn white to indicate the new home point was successfully set.

## RTH OFF

This is the normal switch position and does not initiate an RTH command.

## RTH ON

This manually initiates the RTH function. In a manual RTH, the pilot maintains control of height while the SYNAPSE will command ALTA 8's position over the ground to the home point. In order to initiate Return-to-Home manually, ALTA 8 must first be in Position Mode prior to setting the RTH switch On.

# ORBIT SWITCH

---

The Orbit switch has three settings: Set Orbit Center Point, Orbit Off, and Orbit On.

## SET ORBIT CENTER POINT

Set the center point around which the ALTA 8 will orbit. After obtaining position lock and entering position mode, momentarily toggle the Orbit switch from Off to Set Orbit Center Point and back to Off. The Status Light will blink white to indicate the new center point was successfully set.

## ORBIT OFF

This is the normal switch position and does not initiate the Orbit mode.

## ORBIT ON

This enters Orbit mode. While in Position Mode after having first set the orbit center point, fly the ALTA 8 to the desired orbit radius, and turn the switch to Orbit On. ALTA 8 will automatically yaw towards the center point.

While Orbit On is enabled, use the cyclic roll left and right commands to circle around the target point. Use cyclic pitch forward to decrease the radius of the orbit, and pitch back to increase the radius. While engaged in the orbit, the throttle commands remain active to allow changes in altitude.

Cancel orbit mode by setting the Orbit Switch Off or inputting a yaw command.

### **NOTE**

---

Orbit mode will be canceled automatically if the user flies directly above the center point in order to prevent the machine from spinning about itself abruptly.

---

# DISARM SAFETY SWITCH

---

The Disarm Safety Switch aids in preventing accidental motor disarming while ALTA 8 is in flight and in manual mode. It may be mapped to a two or three-position switch. To set up the Disarm Safety Switch, refer to the Radio Mapping section of this manual.

| 3 POSITION SWITCH | FUNCTION                        |
|-------------------|---------------------------------|
| 1                 | On - Disarming is not possible. |
| 2                 | Off - Disarming is possible.    |
| 3                 | Off - Disarming is possible.    |

| 2 POSITION SWITCH | FUNCTION                        |
|-------------------|---------------------------------|
| 1                 | On - Disarming is not possible. |
| 2                 | Off - Disarming is possible.    |

# STATUS LIGHT

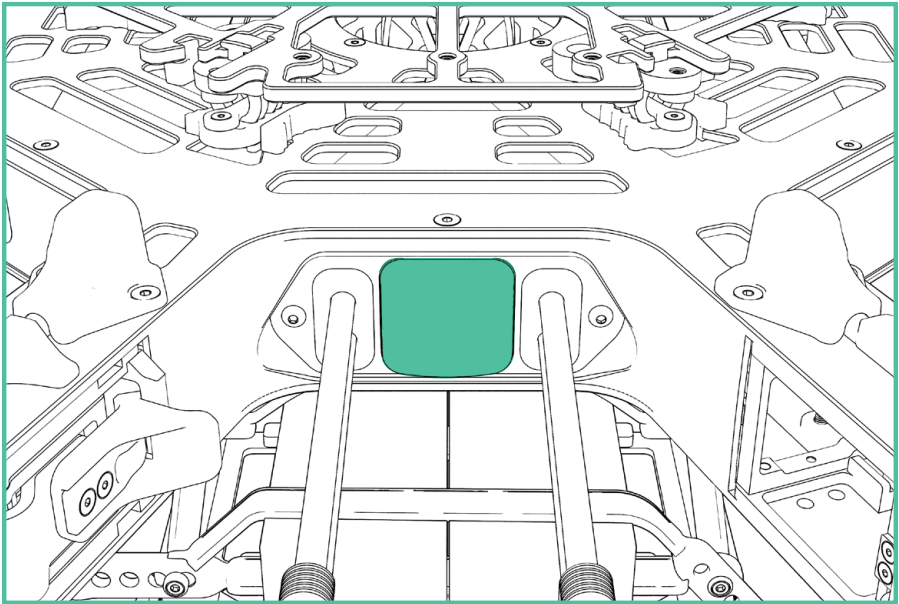

The rear-facing Status Light shows the status of ALTA 8 as it boots, arms, and flies. The following table shows the different meanings of the light in the various flight phases.

| FLIGHT PHASE       | LIGHT COLOR          | MEANING   |
|--------------------|----------------------|---|
| Booting            | Flashing Red + White | Flight controller is booting                      |
| Standby            | Flashing White       | Flight controller is running and disarmed         |
|                    | Flashing Red         | Flight controller is running and not ready to arm |
|                    | Solid Red            | Flight controller boot unsuccessful               |
| Armed              | Off                  | Ready for Flight                                  |
| Flight - all modes | Solid Red            | Flight critical alarm - Land immediately!         |

|                        |                       |   |
|------------------------|-----------------------|---|
| Flight - Manual Mode   | Off                   | Nominal flight status<br>No errors                                      |
|                        | Solid White           | Outside user-defined range, height, or speed limits                     |
|                        | Solid Red             | Flight critical alarm or battery alarm voltage - Land immediately!      |
|                        | Flashing Red          | Battery land voltage - Land immediately!                                |
| Flight - Height Hold   | Off                   | Nominal flight status<br>Height hold inactive                           |
|                        | Slow Flashing White   | Height hold active  |
|                        | Solid or Flashing Red | Flight critical alarm - Land immediately!                               |
| Flight - Position Hold | Off                   | Nominal flight status<br>Height hold inactive<br>Position hold inactive |
|                        | Slow Flashing White   | Height Hold or Position Hold Active                                     |
|                        | Fast Flashing White   | Height Hold and Position Hold Active                                    |
|                        | Solid or Flashing Red | Flight critical alarm - Land immediately!                               |



# ORIENTATION LIGHTS

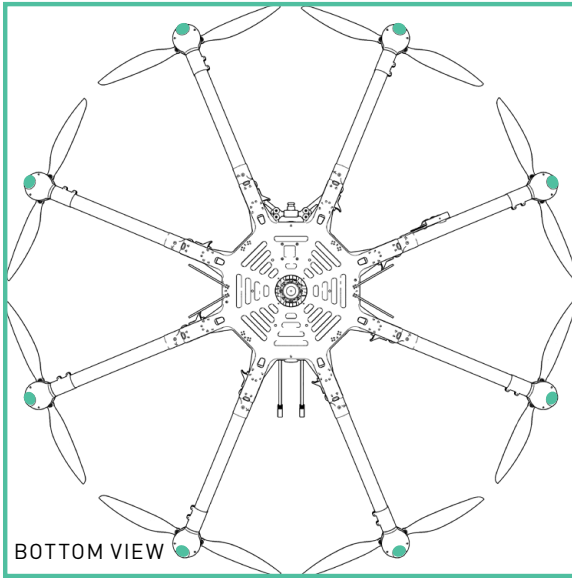

The boom-end mounted Orientation Lights indicate both the orientation of ALTA 8 in flight and the status of the individual motor Electronic Speed Controllers (ESCs) during other operational phases. The following table shows the different meanings of the light colors in the various operational phases.

| FLIGHT PHASE | LIGHT COLOR   | MEANING  |
|--------------|---|--|
| Booting      | Blue  | ESC booting  |
| Standby      | Flashing Green  | ESC booted normally  |
| Armed        | User-defined  | Nominal Status   |
|              | User-defined  | Nominal Status   |
|              | Flashing User-defined   | Flight critical alarm or battery voltage alarm - Land Immediately! |
| Flight       | Flashing Red (only occurs if user has defined all lights to be Off) | Flight critical alarm or battery voltage alarm - Land immediately! |
|              | Firmware Update   | Blue then Yellow   |

# ALARMS

---

ALTA 8 will notify the pilot of critical alarms using the Status Light. These alarms indicate a serious issue has been observed in the behavior of the ALTA 8 that, if not acted upon immediately, can cause loss of control. Never continue a flight when ALTA 8 indicates an alarm.

During an alarm, the Status Light will turn red, and the boom-end mounted Orientation Lights will flash in the user-specified color. If the pilot has set all Orientation Lights Off, they will flash red in the event of an alarm.

## **WARNING**

---

Monitor the Status Light and Orientation Lights frequently during flight. If ALTA 8 displays an alarm, land immediately.

---

# ALTA APP MONITOR

---

The ALTA App includes a flight status monitor that displays information about the health of the ALTA 8 and the various controls that can be selected.

**Boot** indicates if the SYNAPSE booting process has completed successfully. Any issues that prevented a normal boot are indicated here.

**Battery** displays the voltage of the battery packs.

**Status** displays the state of the SYNAPSE flight controller.

**Radio** displays if the SYNAPSE detects a radio controller signal. A LOS warning is displayed if no signal is present.

**GPS** displays if SYNAPSE has resolved a GPS fix or not.

**Sats** displays the number of GPS satellites in view and being received. A minimum of 6 satellites are required in order to enter Position Mode.

**Lock** displays whether a position lock is ready, indicating a valid GPS fix and good heading. This is required before the SYNAPSE will allow switching into Position Mode.

**Height** displays the current height control mode: Manual, Vario if in Height or Position mode and climbing or descending, and Hold.

**Attitude** displays the current attitude control mode.

**Position** displays the current position control mode: Manual, Velocity if in Position mode and moving across the ground, and Hold

**Compass** displays the status of the compass and if the SYNAPSE believes the compass readings are good or bad. If Bad, the compass may require recalibration (see the Compass Calibration section in this manual).

**Station** displays if ALTA 8 is currently over its commanded position over the ground, or if it attempting to fly to it.

**Temp** displays the temperature of the SYNAPSE flight controller board.

## NOTE

---

Connect the ALTA 8 to your iOS or Android device prior to each takeoff in order to monitor performance during flight.

---

## DATA LOGGING

---

ALTA 8 automatically logs flight and control data when ALTA 8 is armed for flight. Data is recorded as a .csv file at a rate of 25 Hz on a microSD card installed on the top of the GPS/Compass module. A table of recorded data is included in Appendix B.

Summarized flight data from an individual flight can also be viewed immediately after landing in the ALTA App's Monitor > Flight Data menu.

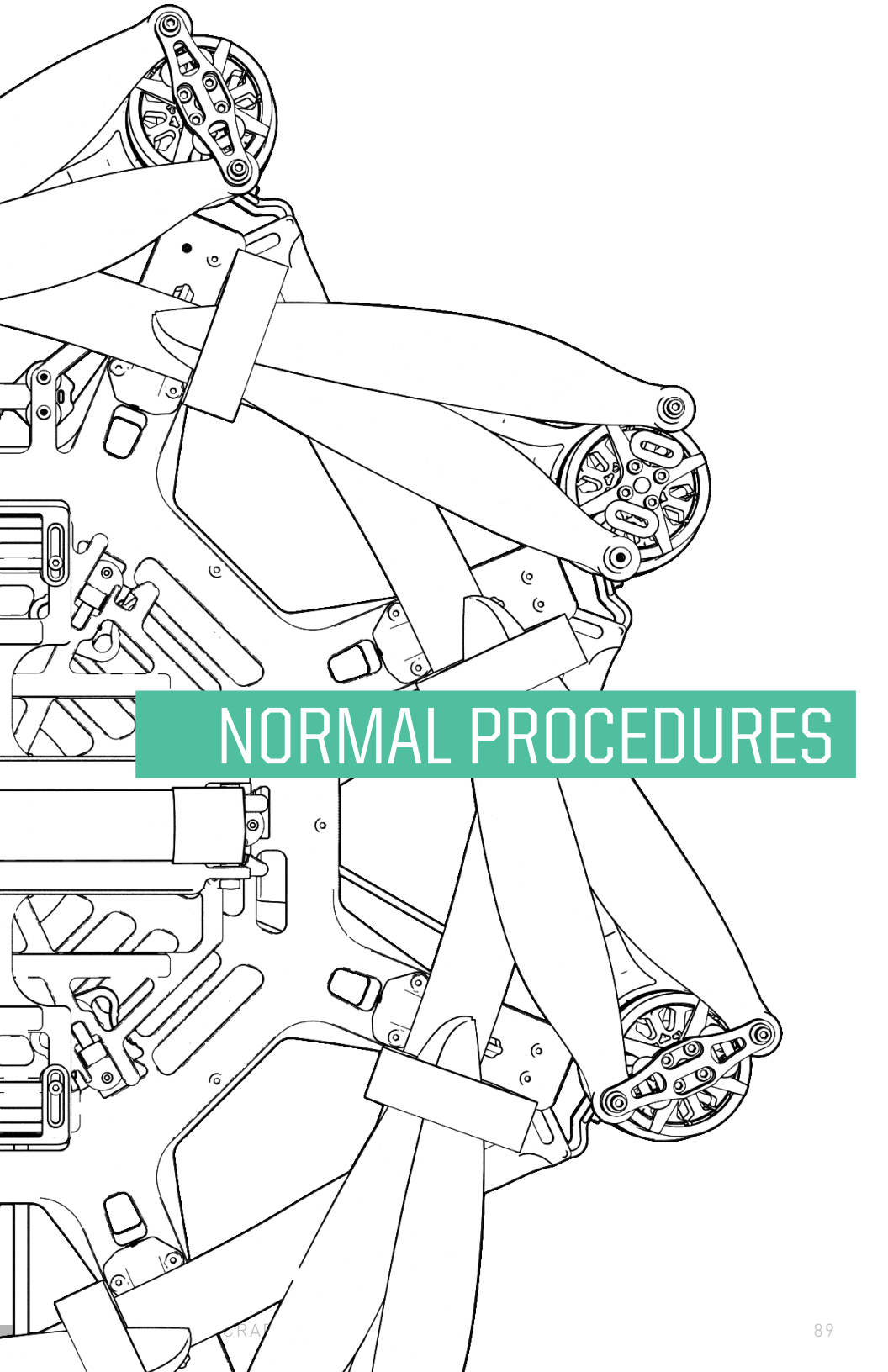

# NORMAL PROCEDURES

# UNPACKING AND SETUP

---

|    |                           |                                 |
|----|---------------------------|---------------------------------|
| 1. | Aircraft                  | REMOVE from case                |
| 2. | Prop protectors           | REMOVE                          |
| 3. | Boom retention clips      | STOW                            |
| 4. | Booms                     | UNFOLD                          |
| 5. | Boom latches              | LOCK                            |
| 6. | Receivers and wiring      | CHECK                           |
| 7. | Isolator cartridges       | SELECT and INSTALL as necessary |
| 8. | Payload mounting location | CONFIGURE as necessary          |

## AMPLIFICATION

To set up ALTA 8 for flight, remove it from the case, and remove the prop protectors. Stow the boom retention clips by folding them down. The clips only fold in one direction and are spring-loaded to stay in open and closed detented positions.

Unfolding the booms is most easily accomplished by unfolding opposite pairs partially. Then unfold the opposite boom pairs completely. ALTA 8 can become unbalanced while unfolding booms individually, so unfolding opposite pairs reduces the possibility of tipping.

Once unfolded, push on the boom latches until they audibly click, indicating the booms are secure. There should be little to no slop in the hinge. Check that the receivers and the electrical connectors that attach to the receivers are secure.

For information on installing isolator cartridges and setting up payload mounting locations, refer to the Isolator Cartridges and Configuring GroundView or SkyView sections of this manual.

## BEFORE STARTING

---

|     |                           |                                |
|-----|---------------------------|--------------------------------|
| 1.  | Payload                   | SECURED                        |
| 2.  | Isolator Cartridges       | VERIFY SECURE                  |
| 3.  | microSD Card              | VERIFY INSTALLED               |
| 4.  | Propellers                | CHECK CONDITION, VERIFY TIGHT  |
| 5.  | Propeller Hubs            | VERIFY SECURE                  |
| 6.  | Motors                    | CHECK CONDITION                |
| 7.  | Radio Controller          | ON, VERIFY TX BATTERY          |
| 8.  | Radio Controller Model    | SELECT                         |
| 9.  | Aircraft Placement        | AWAY from people and obstacles |
| 10. | Battery Pack Voltage      | VERIFY ABOVE 24V               |
| 11. | Battery Packs             | SECURE                         |
| 12. | Battery Leads             | CHECK CONDITION and CONNECT    |
| 13. | Aircraft                  | KEEP STATIONARY                |
| 14. | Flight Controller         | Allow to INITIALIZE            |
| 15. | Status Light              | VERIFY SLOW FLASHING WHITE     |
| 16. | Orientation Lights        | VERIFY FLASHING GREEN          |
| 17. | Receivers                 | VERIFY BOUND                   |
| 18. | ALTA App                  | CONNECT                        |
| 19. | ALTA App Monitor          | VERIFY NO WARNINGS             |
| 20. | Compass Calibration       | CALIBRATE as required          |
| 21. | Radio Control Range Check | AS REQUIRED                    |

## AMPLIFICATION

Check that the payload is secure by checking that the Toad In The Hole quick release lever is pushed in, and that the payload does not slip. Check that all isolator cartridges are locked in place, especially if they have been recently replaced. A microSD card is required to be installed in the GPS/Compass module for reliable compass sensing and data logging.

The blades should be checked for damage, including nicks and scrapes. If a propeller blade has been nicked enough such that it catches a fingernail, it should be replaced. Bolt tightness should be checked by rotating the blade about its length (blade pitch up and down). There should be no slop, and if there is, the bolt and nut should be tightened until the slop is removed. There should be no slop between the propeller hub and the motor.

Motors should spin freely, and there should be no grinding or scraping sound from the motor. The inside of the motor should be free of debris.

Always turn on the radio controller before powering ALTA 8. Follow the battery installation guidance in the Battery Installation section of this manual for battery installation instructions.

While the SYNAPSE flight controller initializes, keep the ALTA 8 as stable as possible. Wedging a foam prop protector between the stationary gimbal or landing gear and the ALTA 8 frame can be used to stabilize ALTA 8 from spinning during this process.

 **NOTE**

---

If ALTA 8 moves during initialization, it may not boot properly and will fail to start or not maintain heading.

---

When it is impossible to initialize ALTA 8 without movement (such as booting on a boat), Motion Booting can be used. It is not recommended to use Motion Booting regularly since it bypasses error checking processes.

During initialization, the Status Light will quickly flash a sequence of red and white lights. At the end of this process, it will begin slow flashing white, indicating SYNAPSE is ready for arming. The Orientation Lights will also begin flashing green. Verify that all motors are flashing green, indicating all ESCs initialized successfully.

Verify that there are no flight warnings by connecting to ALTA 8 via the ALTA App and checking on its status from the App. For more information, see the ALTA App section of this manual.

Perform a manual compass calibration at each new flight location. Survey the anticipated flight path for large ferrous objects or other sources of high magnetic disturbances and determine whether the compass should be disabled in the App.



# BEFORE TAKEOFF

---

|     |                         |                            |
|-----|-------------------------|----------------------------|
| 1.  | Prop Area               | CLEAR                      |
| 2.  | Mode Switch             | MANUAL                     |
| 3.  | Home Switch             | CENTER POSITION            |
| 4.  | Radio Controller        | VERIFY CORRECT MODEL       |
| 5.  | Orbit Switch            | CENTER POSITION            |
| 6.  | Telemetry (if equipped) | CHECK OPERATION            |
| 7.  | ALTA 8                  | ARM                        |
| 8.  | Status Light            | VERIFY OFF                 |
| 9.  | Orientation Lights      | VERIFY USER-DEFINED COLOR  |
| 10. | Motors                  | START and VERIFY OPERATION |
| 11. | Flight Controls         | VERIFY CORRECT             |
| 12. | Throttle                | ADVANCE directly to hover  |
| 13. | Disarm Safety           | ON                         |

## AMPLIFICATION

Prior to start, check the surrounding area to ensure people and objects are clear of ALTA 8 and its props. Also ensure that there are no people or objects between the ALTA 8's takeoff location and its intended flight path.

### **WARNING**

---

ALTA 8's props spin at a high RPM and the ends of the blades move at high speeds. ALTA 8's props can cause severe injury or death or cause damage to objects while they are rotating. Always ensure the area surrounding the props and ALTA 8 is clear of people or objects prior to starting the ALTA 8's motors.

---

ALTA 8 can only be armed for flight when it is in Manual Mode, and the Home Switch is set to RTH Off. To arm, hold full low throttle and full left yaw.

### **WARNING**

---

Do not approach ALTA 8 while it is armed.

---

To start the motors, hold full low throttle and full right yaw. Ensure that all the motors are spinning. Keep the throttle in the lowest position and move the pitch, roll, and yaw controls slightly. ALTA 8 should pitch, roll, and yaw as commanded due to isolator cartridge flex. Ensure that the ALTA 8 behaves as expected. If it does not, shut down ALTA 8 and ensure the propellers are installed in the correct orientation.

---

**ⓘ CAUTION**

Do not make large yaw commands while on the ground with the inverted landing gear installed. Large yaw commands can cause instability.

---

After checking flight control directions, advance the throttle directly from idle to hover throttle. Prior to takeoff, do not advance throttle stick above idle until prepared for flight as this can spool up motors undesirably. While throttling up for takeoff, do not loiter in ground effect. Once in flight, enter a stationary hover, and turn on the Disarm Safety to prevent accidental motor stops while flying. If desired, use the Mode Switch to select Height Mode or Position Mode only after first confirming proper flight performance in Manual Mode.

---

**ⓘ CAUTION**

Only take off in Manual Mode. Attempting to take off in Height or Position Modes may cause ALTA 8 to tip over.

---

---

**⚠ WARNING**

Height Mode and Position Mode are assistive only and are not a replacement for pilot skill and ability. Pilots should be proficient in Manual Mode flight in order to react to emergency situations as required.

---

# AFTER EVERY FLIGHT

---

|     |                          |                            |
|-----|--------------------------|----------------------------|
| 1.  | Mode Switch              | MANUAL                     |
| 2.  | Home Switch              | OFF                        |
| 3.  | Orbit Switch             | OFF                        |
| 4.  | Disarm Safety Switch     | OFF                        |
| 5.  | ALTA 8                   | LAND                       |
| 6.  | Motors                   | DISARM and STOP            |
| 7.  | Orientation Lights       | VERIFY FLASHING GREEN      |
| 8.  | Status LED               | VERIFY SLOW FLASHING WHITE |
| 9.  | ALTA App                 | CHECK for warnings         |
| 10. | Batteries                | DISCONNECT and REMOVE      |
| 11. | Radio Controller Power   | AS REQUIRED                |
| 12. | Aircraft Condition       | INSPECT                    |
| 13. | Motor and Prop Condition | INSPECT                    |
| 14. | Battery Condition        | INSPECT                    |

## AMPLIFICATION

Prior to landing, switch to Manual Mode.

### CAUTION

---

Only land in Manual Mode. Attempting to land in Height or Position Modes may cause ALTA 8 to tip over.

---

Upon landing, disarm the motors by holding full low throttle and full left yaw. This is typically done on the left radio control stick by moving it to the bottom left corner with mode 2 controllers. Disarming can only be done while in Manual Mode. Switch the Disarm Safety to off to allow the motors to stop. Once the motors are stopped and disarmed, the Orientations Lights will flash green, and the Status Light will slowly flash white, indicating it is safe to approach ALTA 8.

### WARNING

---

Only approach ALTA 8 after confirming that it is disarmed by verifying the Status Light and Orientation Light colors.

---

The downwash from the propellers can disturb debris. This debris can be ingested by the propellers or motors and cause damage. After the flight, ensure there is no damage to the propeller blades and that the motors still spin freely and quietly. Take extra care when operating in areas with large amounts of debris, such as in sand, dirt, or gravel.

After flight is also a good time to check the condition of battery packs. Always refer to the battery manufacturer's recommendations for inspection and replacement intervals or requirements.

# AFTER LAST FLIGHT

---

|    |                      |                                  |
|----|----------------------|----------------------------------|
| 1. | Propellers           | FOLD and PLACE inline with booms |
| 2. | Prop Protectors      | INSTALL                          |
| 3. | Boom Latches         | UNLOCK                           |
| 4. | Booms                | FOLD                             |
| 5. | Boom Retention Clips | EXTEND                           |
| 6. | Payload              | REMOVE                           |
| 7. | ALTA 8               | INSERT into case                 |

## AMPLIFICATION

Fold propeller blades and install foam prop protectors to decrease the risk of damaging the propellers while packing ALTA 8. Keeping ALTA 8 on the payload or landing gear easily facilitates the folding process as ALTA 8 may be turned on the Toad In The Hole adapter while folding the propellers and booms. Folding the booms in opposing pairs can help maintain balance and reduce the likelihood of tipping.

Make sure that the handle is aligned front-to-back with the battery leads facing to the right when putting ALTA 8 in the included case. Pay special attention to optional accessories if installed (FPV camera and Tx) to make sure they are located in the foam cavity properly.

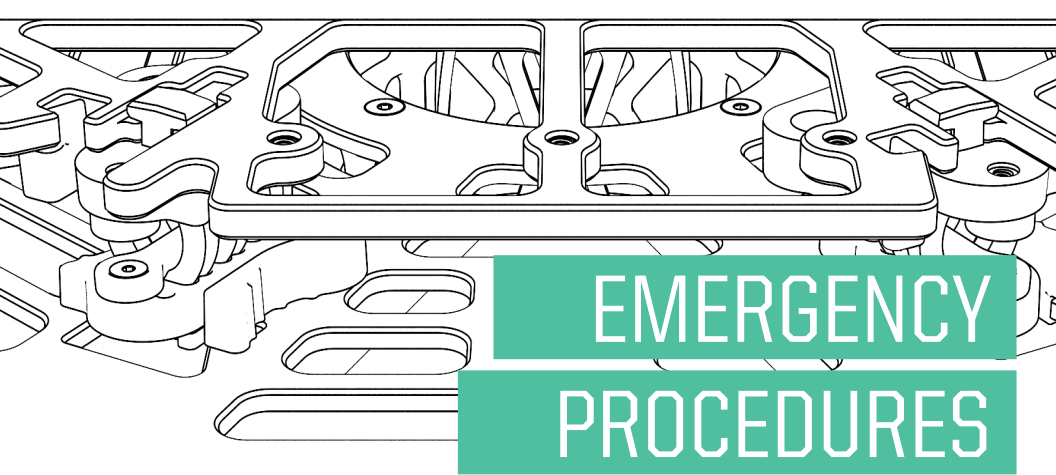
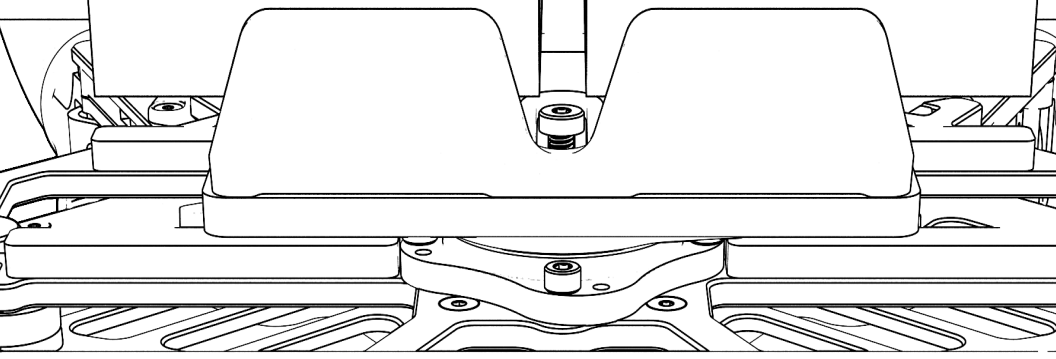

# EMERGENCY PROCEDURES

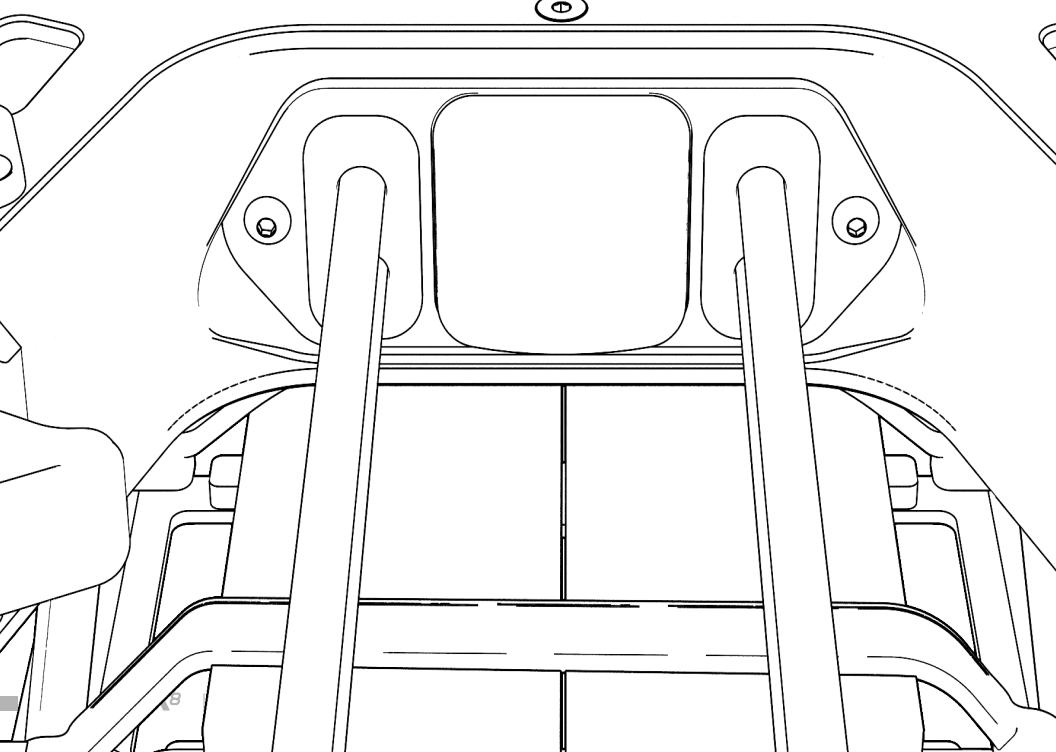

# EMERGENCY GUIDANCE

---

The emergency procedures listed in this section are the recommended practices for handling the aircraft in the event of an aircraft emergency. This guidance should be considered and applied as necessary.

The risk of an emergency occurring can be reduced substantially through proper aircraft maintenance, by performing thorough inspections before and after all flights, and with careful pre-flight planning.

Emergency situations are dynamic events, and not all conditions or procedures can be anticipated or applied during the event. These procedures are not a substitute for a thorough understanding of aircraft systems and sound pilot judgment.

In general, if an emergency occurs, three basic actions can be applied to most situations:

1. **Maintain aircraft control** - Small emergencies can quickly escalate if the pilot is distracted attempting to determine or troubleshoot the problem. Always maintain visual contact with the aircraft during an emergency to reduce the likelihood of losing orientation.
2. **Analyze the situation** - Once the aircraft is stabilized, begin to assess the cause of the emergency if practical.
3. **Take appropriate action** - In many cases, the appropriate action will be to land the aircraft as soon as possible. Always consider the safety of yourself and others before attempting to save the aircraft in an emergency.

# ALARM INDICATION (FLASHING OR SOLID RED LIGHT)

---

|    |             |                          |
|----|-------------|--------------------------|
| 1. | Mode Switch | MANUAL                   |
| 2. | ALTA 8      | LAND as soon as possible |
| 3. | ALTA App    | OPEN MONITOR             |

## AMPLIFICATION

Alarms are displayed if the flight controller determines there is a condition present that can adversely affect the safety of the flight. Alarms are indicated by the Status Light turning or flashing Red (depending on the flight mode) and the Orientation Lights flashing.

Land as soon as possible when the Status Light and/or Orientation Lights indicate a warning, and investigate the problem while ALTA 8 is safely on the ground. It is best practice to set the mode switch to Manual when an Alarm is observed to maintain full control authority of ALTA 8.



# PILOT LOSS OF ALTA 8 ORIENTATION

---

|    |                |                  |
|----|----------------|------------------|
| 1. | Control Inputs | NEUTRALIZE       |
| 2. | Mode Switch    | POSITION         |
| 3. | Yaw            | NOSE AWAY        |
| 4. | Roll           | VERIFY DIRECTION |

## AMPLIFICATION

Regaining spatial orientation as quickly as possible is most important. If the pilot loses orientation of ALTA 8, control inputs will not give the expected result, so neutralize controls by centering the throttle/yaw and pitch/roll sticks to stabilize motion. If a good GPS signal is available, enable Position Mode so ALTA 8 will stay in one place.

Use yaw only to reorient ALTA 8 so the nose is pointed away, then use the roll control to verify the orientation of ALTA 8.

### **WARNING**

---

Position Mode may not function as expected if Position Lock has not been achieved. It is best practice to wait for position lock prior to takeoff even if Position Mode is not planned to be used during the flight.

---

# UNEXPECTED FLIGHT CONTROLLER BEHAVIOR

---

|                         |                |                          |
|-------------------------|----------------|--------------------------|
| 1.                      | Control Inputs | NEUTRALIZE               |
| 2.                      | Mode Switch    | MANUAL                   |
| If the problem persists |                |                          |
| 3.                      | ALTA 8         | LAND as soon as possible |

## AMPLIFICATION

If the ALTA 8 behaves unexpectedly, neutralize controls by centering the throttle/yaw and pitch/roll sticks and observe ALTA 8. If it is still flying in an uncommanded manner in either Height or Position Mode, switch to Manual Mode. In most cases, unexpected behavior is due to erroneous sensor readings, degraded GPS signal reception, or compass issue.

If the unexpected behavior occurred while in Manual mode, land as soon as possible and check the ALTA App for any warnings.

# BATTERY EXHAUSTION

If battery cell voltage is below Alarm Voltage (all flight modes)

- |    |                    |                                     |
|----|--------------------|-------------------------------------|
| 1. | Status Light       | ILLUMINATES RED (solid or blinking) |
| 2. | Orientation Lights | FLASH                               |
| 3. | ALTA 8             | LAND as soon as possible            |

If battery cell voltage is below Land Voltage **while flying in Manual Mode**

- |    |                    |   |
|----|--------------------|---|
| 1. | Status Light       | FLASH RED   |
| 2. | Orientation Lights | FLASH   |
| 3. | ALTA 8             | LAND as soon as possible<br>(Autoland is not initiated) |

If battery cell voltage is below Land Voltage **while flying in Height or Position Mode**

- |    |                    |                                      |
|----|--------------------|--------------------------------------|
| 1. | Status Light       | ILLUMINATES RED (solid or blinking)  |
| 2. | Orientation Lights | FLASH                                |
| 3. | ALTA 8             | AUTOLAND is initiated automatically  |
| 4. | Pitch and Roll     | MANEUVER away from people or objects |

## AMPLIFICATION

If the battery cell voltage drops below the Alarm Voltage, the Status Light will turn solid red in Manual Mode or flash red if in Height Hold or Position Hold. The orientation lights will flash in the user-defined colors. If all orientation lights have been specified off, the orientation lights will flash red. Terminate the flight and land as soon as possible.

If the battery cell voltage drops below the Land Voltage, the Status Light will flash red. The orientation lights will flash as described above. In Manual Mode, the pilot will remain in full control of the ALTA. In Height or Position Mode, ALTA will begin to Autoland, and pitch and roll commands will remain active. During the time ALTA is descending, use pitch and roll to avoid people and objects during the descent and landing.

### **WARNING**

ALTA 8 will not Autoland if it is in Manual Mode. Full throttle authority is available to the pilot in a battery exhaustion event.

# RADIO LOSS OF SIGNAL (LOS)

---

|    |                    |                |
|----|--------------------|----------------|
| 1. | Controller Battery | CHECK          |
| 2. | Controller Antenna | REPOSITION     |
| 3. | Mode Switch        | POSITION       |
| 4. | Home Switch        | RETURN-TO-HOME |

## AMPLIFICATION

Loss of Signal (LOS) can occur if the radio controller stops transmitting a signal, or if ALTA 8 is too far away to receive it. In the event ALTA 8 detects a LOS, it will automatically execute a Return-to-Home or Autoland as configured in the App if using an S.Bus/S.Bus2 or DSM2/DSMX radio type. While the ALTA 8 includes these emergency control modes, it is always recommended to attempt to regain signal link with ALTA 8 to keep the pilot in control of the aircraft.

Move the antenna orientation for best signal strength. Ensure the radio antenna matches the direction of the receiver antennae. Move the radio away from objects to get a clear line-of-sight to ALTA 8.

Set the Mode switch to Position and the Home switch to Return-to-Home so ALTA 8 will continue to approach the home point if the signal is momentarily regained, resulting in higher likelihood of regaining full signal reception.

### **NOTE**

---

If efforts to regain control signal are unsuccessful, ALTA 8 will begin either the Return-to-Home and Autoland sequence as configured in the App. Refer to the Flight Controller Modes section of this manual for additional information regarding functionality available with specific radio types.

---

# LOSS OF FPV SIGNAL

---

|    |                |                                       |
|----|----------------|---------------------------------------|
| 1. | Control Inputs | AS REQUIRED                           |
| 2. | Visual Contact | MAINTAIN                              |
| 3. | ALTA 8         | POSITION for optimal signal reception |

If visual contact or FPV signal is not maintained

|    |             |                |
|----|-------------|----------------|
| 1. | Mode Switch | POSITION       |
| 2. | Home Switch | RETURN TO HOME |
| 3. | Throttle    | AS REQUIRED    |

## AMPLIFICATION

An FPV Loss of Signal (LOS) can occur if the aircraft flies out of range or if it flies behind an object that interrupts the signal. Maintaining visual contact is the preferred method to reestablish control of the aircraft, either with the pilot seeing the aircraft, or by the use of a visual observer.

Yawing the aircraft can help signal reception if the body of the aircraft is blocking the line of sight between the transmitter and receiver antennas.

If FPV signal or visual contact cannot be maintained, setting the Mode switch to Position Mode and enabling Return-to-Home can be used to bring the aircraft back to signal reception range.

### **WARNING**

---

It is the responsibility of the pilot to see and avoid other aircraft, people, or obstacles. Always maintain direct line of sight with ALTA 8 during flight, use visual observers as operations require, and follow local regulations regarding see-and-avoid requirements.

---

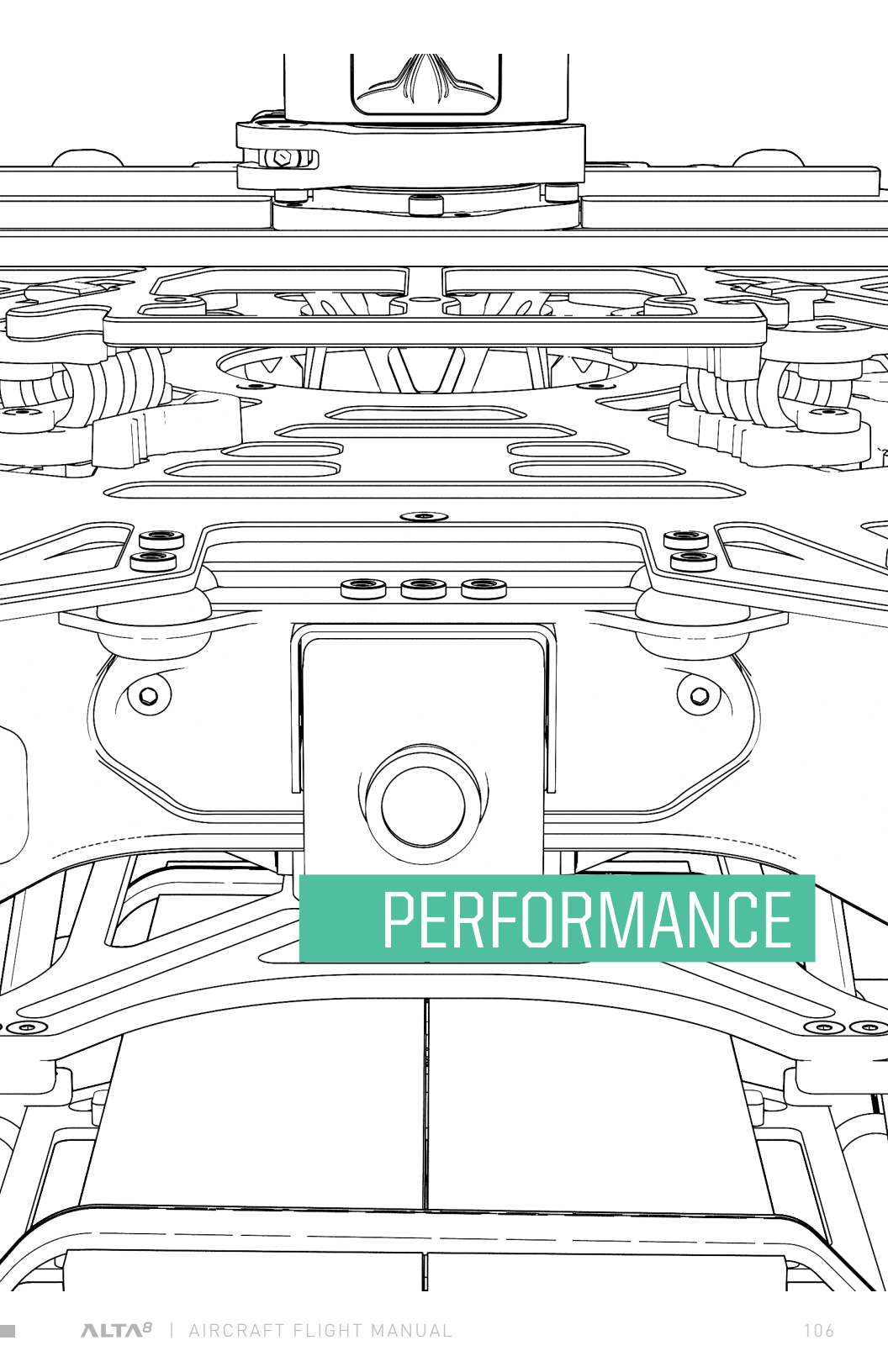

# PERFORMANCE

# WEIGHT / ENDURANCE PERFORMANCE DATA

Conditions:

|          |                |
|----------|----------------|
| Altitude | Sea Level, ISA |
| Winds    | Zero           |

ALTA 8 Approximate Flight Times vs. Payload

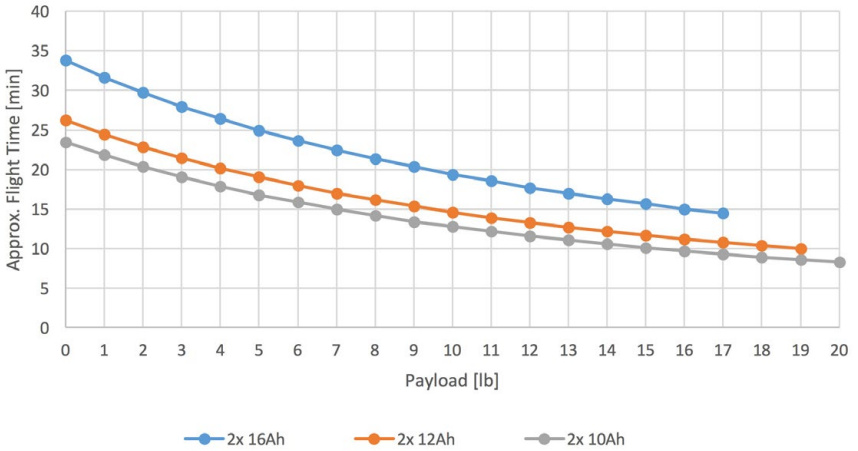

## ALTA 8 ALLOWABLE GROSS WEIGHT

As altitude and temperature increase, the density of the air decreases. Consequently, ALTA 8's thrust will decrease. The following table describes maximum gross weight limits with respect to altitude and temperature.

| Press Alt       | 0°C (32°F)                |                           | 10°C (50°F)               |                           | 20°C (68°F)               |                           | 30°C (86°F)               |                           | 40°C (104°F)              |                           |
|-----------------|---------------------------|---------------------------|---------------------------|---------------------------|---------------------------|---------------------------|---------------------------|---------------------------|---------------------------|---------------------------|
|                 | Maximum Gross Weight (lb) | Maximum Gross Weight (kg) | Maximum Gross Weight (lb) | Maximum Gross Weight (kg) | Maximum Gross Weight (lb) | Maximum Gross Weight (kg) | Maximum Gross Weight (lb) | Maximum Gross Weight (kg) | Maximum Gross Weight (lb) | Maximum Gross Weight (kg) |
| Sea Level       | 40.0                      | 18.1                      | 40.0                      | 18.1                      | 39.3                      | 17.8                      | 38.0                      | 17.2                      | 36.8                      | 16.7                      |
| 305m (1000ft)   | 40.0                      | 18.1                      | 39.3                      | 17.8                      | 37.9                      | 17.2                      | 36.7                      | 16.6                      | 35.5                      | 16.1                      |
| 610m (2000ft)   | 39.2                      | 17.8                      | 37.8                      | 17.2                      | 36.6                      | 16.6                      | 35.4                      | 16.0                      | 34.2                      | 15.5                      |
| 914m (3000ft)   | 37.8                      | 17.2                      | 36.5                      | 16.5                      | 35.2                      | 16.0                      | 34.1                      | 15.5                      | 33.0                      | 15.0                      |
| 1219m (4000ft)  | 36.4                      | 16.5                      | 35.2                      | 15.9                      | 34.0                      | 15.4                      | 32.8                      | 14.9                      | 31.8                      | 14.4                      |
| 1524m (5000ft)  | 35.1                      | 15.9                      | 33.9                      | 15.4                      | 32.7                      | 14.8                      | 31.6                      | 14.3                      | 30.6                      | 13.9                      |
| 1829m (6000ft)  | 33.8                      | 15.3                      | 32.6                      | 14.8                      | 31.5                      | 14.3                      | 30.5                      | 13.8                      | 29.5                      | 13.4                      |
| 2134m (7000ft)  | 32.6                      | 14.8                      | 31.4                      | 14.2                      | 30.3                      | 13.8                      | 29.3                      | 13.3                      | 28.4                      | 12.9                      |
| 2438m (8000ft)  | 31.3                      | 14.2                      | 30.2                      | 13.7                      | 29.2                      | 13.2                      | 28.2                      | 12.8                      | 27.3                      | 12.4                      |
| 2743m (9000ft)  | 30.2                      | 13.7                      | 29.1                      | 13.2                      | 28.1                      | 12.7                      | 27.2                      | 12.3                      | 26.3                      | 11.9                      |
| 3048m (10000ft) | 29.0                      | 13.2                      | 28.0                      | 12.7                      | 27.0                      | 12.3                      | 26.1                      | 11.9                      | 25.3                      | 11.5                      |



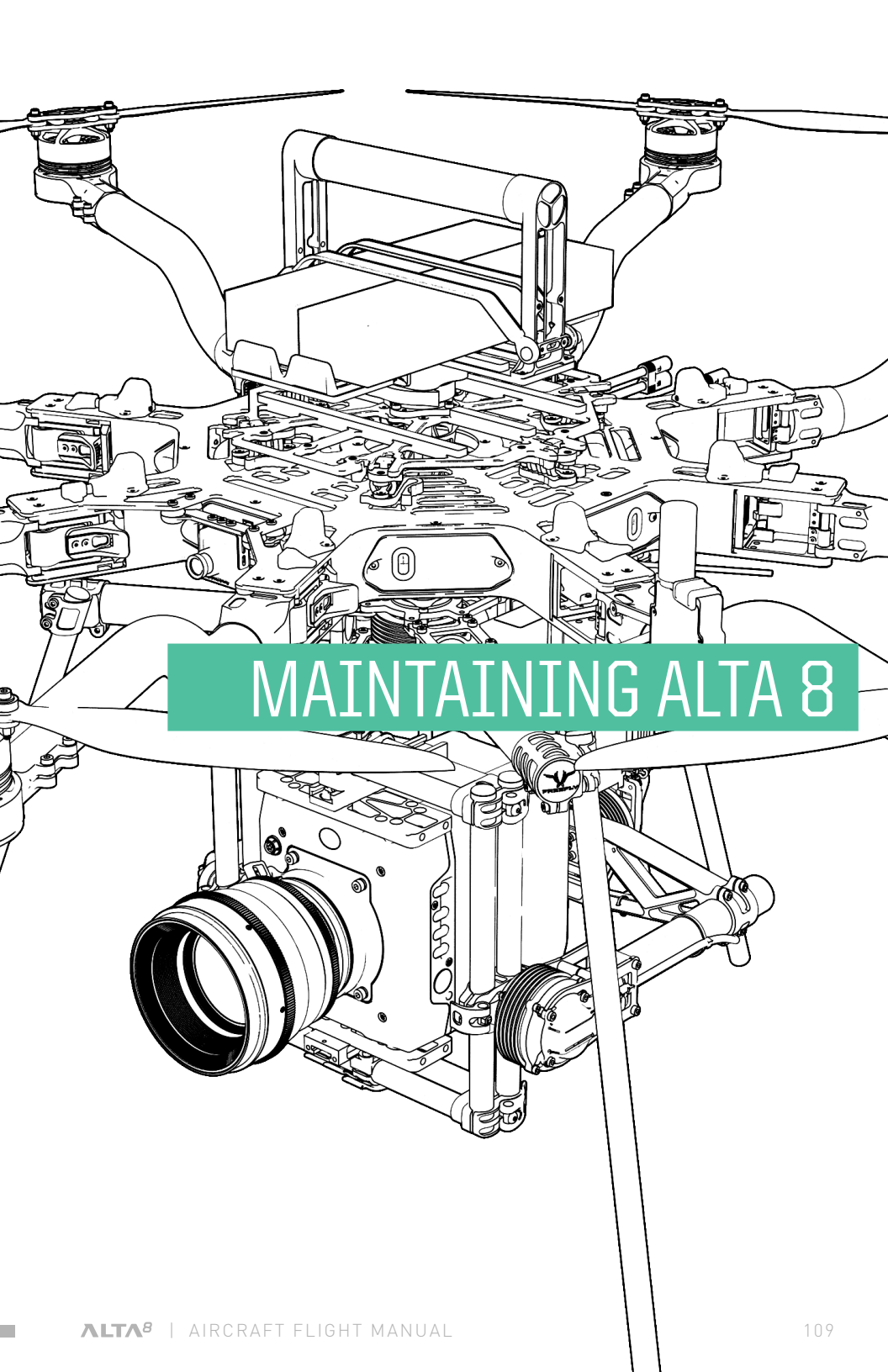

# MAINTAINING ALTA 8

## CHASSIS

ALTA 8 ships from the factory with motors precisely aligned to minimize the difference in motor speed between clockwise turning and counterclockwise turning motors while in flight. Opening the chassis by removing the screws that attach either the top or bottom chassis plates affects this alignment and may reduce ALTA 8 performance.

### **NOTE**

---

Do not open the ALTA 8 chassis.  
Opening the chassis affects factory alignment.

---

All user maintainable items are outside the chassis and do not require the removal of screws attaching the top or bottom chassis plates.

## USE OF THREADLOCKER

Bolts and screws this manual identifies as needing to be removed or replaced do not typically require threadlocking compound. This includes the screws holding on the handle, battery retention strap studs, battery stops, closeout panels, and the top male Toad In The Hole adapter. In addition, fasteners that attach to nuts with a nylon locking feature (nylock nuts) do not require threadlocker.

All structural fasteners require the use of threadlock. This includes chassis screws, lower male Toad In The Hole adapter, motor attachment fasteners, and the four M3 x 8 socket head bolts that attach the folding propeller to the motor. Typically, a low strength threadlocker (such as Loctite Purple 222) is used on structural fasteners.

## FASTENER INSTALLATION

The Freely hex drivers included with ALTA 8 are designed to limit the torque that can be applied to each bolt or screw and help prevent stripping the fastener head.

Thread all fasteners into their respective holes until snug. This is when the fastener head bottoms out and lightly clamps the two mating parts together.

To prevent excessive tightening and damaging the fastener or parts, twist the driver from the smaller diameter knurled section of the tool between your thumb and index finger for small fasteners (under size M3) or with your thumb and two forefingers for larger fasteners (size M3 and larger).

# MAINTENANCE ITEMS

## PROPELLERS

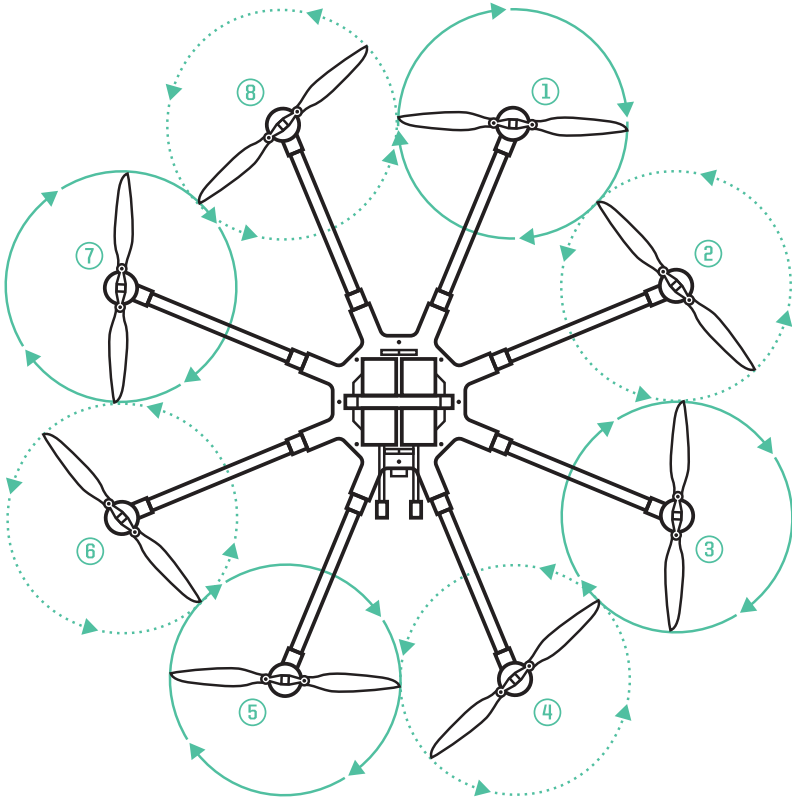

Propeller blades should be removed when making a change to the configuration of the ALTA 8 to prevent propeller strikes in the event of unintentional motor starts and should be replaced on an as needed basis if they become damaged. Generally, a nick on the leading edge that is large enough to catch a fingernail indicates that the propeller should be replaced. If the blade composite structure becomes delaminated, the propeller should be replaced.

Freefly makes folding propeller assemblies available that include the blades and propeller hub fully assembled and factory balanced. They are available in clockwise and counterclockwise orientations.

### ⓘ CAUTION

Only use propellers supplied by Freefly on ALTA 8. Use of third-party propellers can cause motor instability, overheating, and failure.

The folding propellers are installed on the motors with four M3×8 socket head bolts.

### ⓘ CAUTION

---

Always use a threadlocking compound on the bolt threads that attach the propeller hub to the motor.

---

Odd numbered booms (1, 3, 5 and 7) use clockwise rotating propellers when looking from the top down, and even numbered booms (2, 4, 6 and 8) use counterclockwise rotating propellers.

### ⚠ WARNING

---

Always check to ensure the correct propeller rotation direction and correct propeller prior to flight. Propellers that spin in the incorrect direction will cause ALTA 8 to be uncontrollable.

---

## REPLACING PROPELLER BUMPERS

Under normal use, propeller bumpers (see exploded view figure on the next page) may split and fall out of the folding propeller assembly. Six spare bumpers are provided with the ALTA 8. To replace the bumper, disassembly of the folding propeller is required.

Start by removing the M3 x 19 bolt and nylon nut. Pull off the upper prop adapter. The two bumpers are held in place by cylindrical features in the lower prop adapter. Replace the worn or split bumper with a new one.

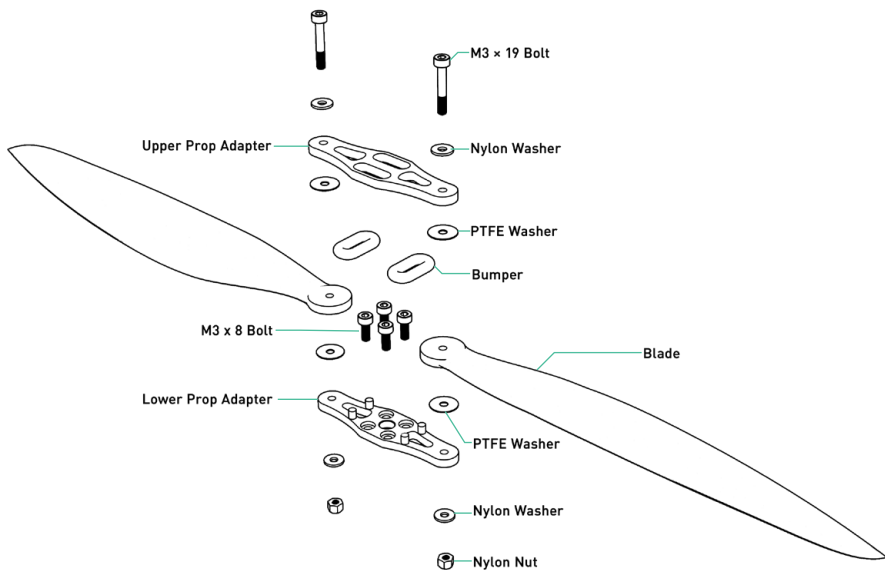

To reassemble, follow the part layout in the figure above. Note that there are two different types of washers, one made of nylon and the other made of PTFE. The nylon washer is smaller in width and thicker and is installed between the nut or bolt head and the two prop adapters. The PTFE washer is wider and thinner and is installed between the prop blades and prop adapters.

**NOTE**

Propeller blades are balanced and paired individually. Do not mix and match individual propeller blades when reassembling. Unbalanced propellers can affect flight performance.

## EVERY 15 FLIGHTS

ALTA 8 is designed to be as low-maintenance as possible.

It is recommended to check ALTA 8's fasteners regularly. This check should occur roughly after every 15 flights, dependent upon the level of vibration ALTA 8 experiences in flight or during handling. To check ALTA 8's fasteners, apply a tightening torque to each fastener on the chassis using the supplied hex drivers. The fasteners should not slip.

If a fastener does slip, tighten it using the methods described in the Fastener Installation section. Do not apply additional threadlocking compound unless the fastener has repeatedly come loose.

## EVERY 15 FLIGHT HOURS

The following should be checked after every 15 hours of flight.

### FASTENER TIGHTNESS

Check the tightness of the following fasteners:

- » Motor mount bolts
- » Prop hub bolts
- » Prop bolts
- » Top and bottom chassis bolts
- » Closeout panel bolts
- » FPV camera mounting plate bolts
- » Accessory mounting plate bolts
- » GPS/Compass mounting bolts

### INSPECTION

Inspect the following items. Replace if worn.

- » Propeller blades
- » Prop bumpers

### HINGE LATCH TIGHTNESS

Check hinge latching tightness by closing the hinge. There should be a firm closing force and click. Adjust the tension by using a 1.5mm hex wrench on the set screw located under the hinge latch.

## REPLACEMENT OF PARTS

Spare or replacement parts are available for sale separately at [www.freeflysystems.com](http://www.freeflysystems.com). Please refer to the company store for a current listing of all available spare parts.

# FIRMWARE UPDATE PROCESS

---

## **NOTE**

Carefully follow in-app instructions for saving and restoring ALTA 8 configuration settings during the firmware update process.

---

## **WARNING**

Test radio channels, arming, and disarming behavior after firmware updates to ensure radio mapping has been preserved. Incorrect radio mapping can lead to loss of control.

---

SYNAPSE firmware is updated using the ALTA App. New app updates may include new firmware installations. To update firmware:

1. Provide power to ALTA 8
  - a. Install and plug in a fully charged flight pack or
  - b. Plug in the USB-Futaba cable to an available receiver port (Futaba and PPM receivers only)
2. Open the ALTA App
3. Open Monitor > Updates
4. The latest firmware included with the app release is compared with the ALTA 8 firmware. If a new release is available, the app will provide a notification
5. Tap the Install button in the App if an update is available, and follow the prompts to save the current configuration
6. Wait until the firmware is loaded and ALTA 8 has booted as indicated by the Status and Orientation Lights — Do not power down ALTA 8 during this time
7. Reload saved configuration

# MOTOR ALIGNMENT

---

ALTA 8's motors are aligned at the factory at an angle of  $\pm 2.5^\circ$  relative to the chassis. This slight angle improves aircraft yaw authority and reduces the possibility of clockwise and counterclockwise turning motors from spinning at different speeds during stable hover. This alignment can be lost when opening the ALTA 8 chassis or if a boom needs to be replaced.

If the motors need to be realigned, follow the realignment procedure, then verify realignment was successful using the ALTA Flight Data Viewer, available at [www.freeflysystems.com](http://www.freeflysystems.com).

To perform a realignment, Freefly recommends using a small digital angle gauge with a flat surface so it can rest on the bottom of the motor mount (for example, the Wixey WR300 angle gauge).

## MOTOR REALIGNMENT PROCEDURE

1. Place ALTA 8 on a level surface.
2. Place a digital angle gauge on the chassis next to the boom facing outwards.

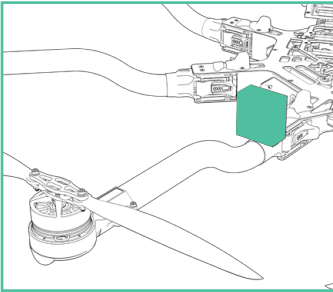

3. Zero the angle gauge.
4. Starting at motor 1, place the digital angle gauge on the flat surface of the motor mount with the gauge facing outwards.

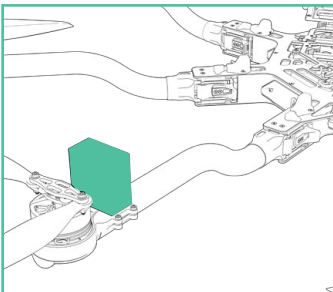



5. If the gauge reads a value outside the range  $2.5^{\circ} \pm 0.1^{\circ}$ , loosen the motor mount clamping bolts. While placing slight inward pressure on the motor, rotate the motor until the angle gauge indicates  $2.5^{\circ} \pm 0.1^{\circ}$ . When viewed from the end of the boom:
  - a. Motors 1, 3, 5 and 7 should be rotated clockwise.

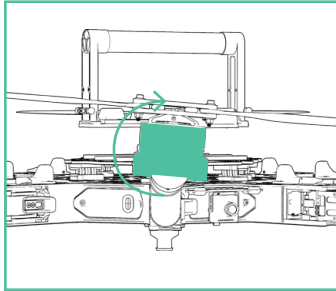

- b. Motors 2, 4, 6 and 8 should be rotated counterclockwise.

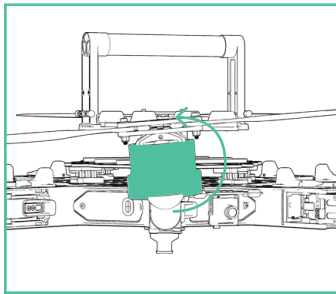

 **NOTE**

---

When rotating the motor, do not pull outwards on it.

---

6. Apply threadlock as required (Loctite 222 recommended), and tighten the motor mount bolts to 0.8 N-m [7 in-lbs]. Do not over-torque the bolts.
7. Repeat steps 2 through 6 for the additional motors.
8. After aligning motors, recheck motor mount alignment and clamping bolt tightness.

## MOTOR ALIGNMENT VERIFICATION FLIGHT TEST PROCEDURE

1. Complete the Unpacking and Setup, Before Starting and Before Takeoff checklists.
2. Enter a hover for at least 10 seconds. Do not yaw during the hover.

3. Perform the 'After Every Flight' checklist.
4. Retrieve the microSD card from the GPS module and open it with a computer.
5. Open the ALTA Flight Data Viewer.
6. Drag and drop the latest .csv data log file of the test flight from the microSD card on to the ALTA Flight Data Viewer window.
7. Under the Data Seeker section, select Hover from the Seek Event drop down box.
8. In the Flight Statistics section, look at the Yaw CW Bias value. It should be within +/- 5%. If Yaw CW Bias is outside +/- 5%, recheck motor alignment.

 **NOTE**

---

If the ALTA Flight Data Viewer is unavailable or cannot be used on your operating system, yaw bias can be found at the bottom of the .csv data log for that flight.

---

# GUIDELINES FOLLOWING AN ACCIDENT

---

Extra precautions should be taken following an accident, including a crash, tip over, propeller strikes with solid bodies, or other abnormally stressing events. Contact Freely Customer Support immediately after an accident for guidance as field inspections are no substitute for consultation and direct inspection and repair of damage by Freely.

Freely Customer Support can be reached at [support@freelysystems.com](mailto:support@freelysystems.com) or by phone at +1 (425) 485-5500.

## ⚠ CAUTION

---

ALTA 8 is a precisely tuned flying machine with sensitive electronics and may become damaged or adversely affected by crashes, tip overs, propeller strikes with solid bodies, or other abnormally stressing events. Freely recommends contacting Customer Support immediately for guidance in case of any of these events. Field inspections are no substitute for consultation and direct inspection and repair of damage by Freely.

---

Typical inspection points after an accident may include, but not be limited to, the following to gauge the flight-worthiness of ALTA 8 prior to subsequent flights:

- » Propeller blade and hub damage
- » Propeller tip spacing
- » Motor alignment
- » Chassis plate damage
- » The Toad In The Hole spacer in the center of the ALTA 8
- » Booms for damage or cracking
- » Position light covers
- » Landing gear
- » Closeout panels
- » Hinge frame alignment
- » Hinge tension-compression link and latch

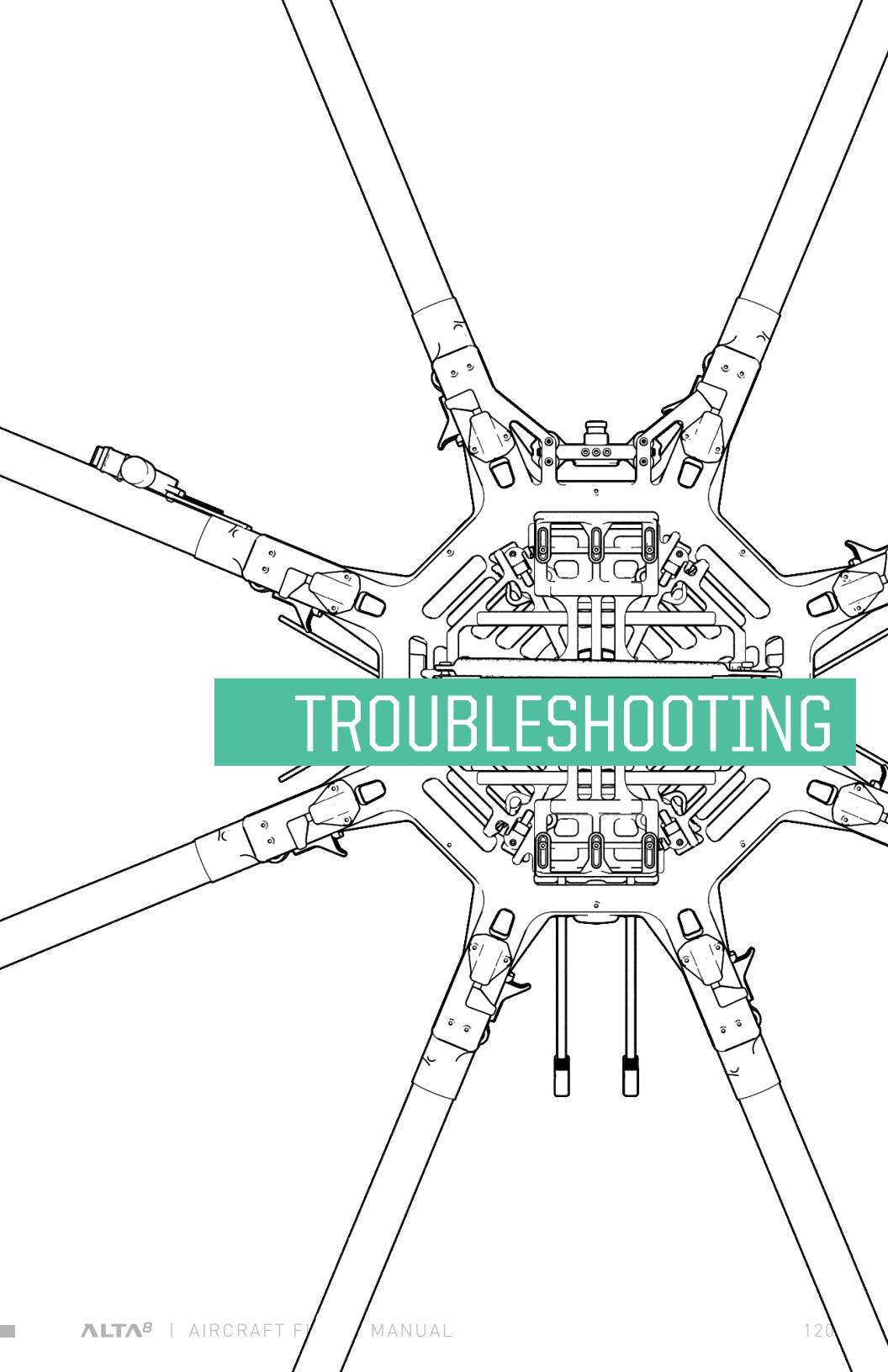

# TROUBLESHOOTING

## FIRMWARE UPDATE

| SYMPTOM                                | POTENTIAL CAUSE   | POTENTIAL SOLUTION  |
|--|---|---|
| Firmware update only completes halfway | WiFi connection between ALTA 8 and mobile device lost during update | Remove sources of radio frequency interference, or move to a new location. Restart firmware update. |

## GENERAL WARNINGS

| SYMPTOM               | POTENTIAL CAUSE                          | POTENTIAL SOLUTION   |
|-----------------------|--|--|
| Boot Fail             | Voltage limits exceeded                  | Check voltage of flight packs and replace as necessary                                     |
|                       | Compass readings out of limits           | Check surroundings and boot in an area away from ferrous objects. Recalibrate the compass. |
| Compass Warning       | microSD card is missing                  | Check the microSD card is installed  |
|                       | microSD card is corrupt                  | Remove the microSD and reformat FAT32. If problem persists, replace with a new card.       |
|                       | Invalid compass calibration              | Recalibrate the compass  |
| GPS Warning           | GPS/Compass Unit has become disconnected | Check the GPS/Compass unit wiring for damage   |
| Accelerometer Warning | Hard landing                             | Reboot ALTA 8  |
| Motor Warning         | ESC or Motor failure or error            | Contact Freefly Customer Support immediately. Do not continue flying ALTA 8.               |

## FLIGHT CONTROLLER

| SYMPTOM              | POTENTIAL CAUSE             | POTENTIAL SOLUTION  |
|----------------------|-----------------------------|---|
| ALTA 8 will not arm  | Home Switch not Off         | Move Home Switch to Off   |
|                      | Mode Switch not in Manual   | Move Mode Switch to manual  |
|                      | Radio not bound             | Follow radio controller manufacturer's binding procedure  |
|                      | Radio not mapped properly   | Check ALTA App radio mapping charts for correct behavior<br>Adjust mapping as necessary   |
|                      | SYNAPSE boot not successful | Power cycle ALTA 8. Ensure it does not move during boot<br>If ALTA 8 must move during boot (such as on a moving platform), use Motion Booting |
| Motors will not stop | Mode Switch not in Manual   | Move Mode Switch to manual  |
|                      | Disarm Safety On            | Move Arm Enable Switch to Allow Disarm  |

## FLIGHT BEHAVIOR

| SYMPTOM                                      | POTENTIAL CAUSE                     | POTENTIAL SOLUTION   |
|--|-------------------------------------|--|
| Unexpected flight behavior                   | Tuning too high or too low          | Revert tuning to the last known working configuration<br>Set tuning back to default values |
| ALTA 8 does not maintain level pitch or roll | Pitch or Roll Trim position not set | Use the ALTA app to set the appropriate pitch and roll trim                                |

|  |  |   |
|--|--|---|
| ALTA 8 oscillates or vibrates during flight                    | Tuning too high or too low               | Check flight settings and tuning parameters in the App. Revert tuning to the last known working configuration. Re-tune.               |
|  | Propeller damage                         | Check for damage to propeller blades. Replace with spares as required.  |
|  | Propeller blades unbalanced              | Replace with spares as required. Propeller blades are balanced and matched at the factory.  |
|  | Hinge or motor misalignment              | Thoroughly inspect ALTA 8 following any accident. Contact Freely for further inspection and assessment.                               |
| ALTA 8 is sluggish in response to commands                     | Tuning too low                           | Check tuning in ALTA 8 and adjust as required   |
|  | Flight weight is over limit              | Weigh the ALTA 8 and compare to the Allowable Gross Weight table in this manual. Remove weight.                                       |
|  | Velocity or Climb Rate set too low       | Check settings in the ALTA App. Check the position of the slider clamps on the Radio controller. Increase as required                 |
| ALTA 8 ascends or descends when switching between flight modes | Hover Throttle set incorrectly           | Follow the instructions listed in the ALTA 8 Flight Parameters section of this manual to adjust Hover Throttle                        |
| ALTA 8 does not maintain heading                               | Yaw during boot                          | Re-initialize SYNAPSE while keeping ALTA 8 stationary in all directions   |
| Unexpected behavior in Position Mode                           | Position lock not achieved               | Monitor ALTA App and takeoff only after Position Lock has been achieved with strong GPS signal  |
|  | Incorrect heading due to yaw during boot | Re-initialize SYNAPSE while keeping ALTA 8 stationary in all directions   |
|  | Compass corruption or calibration        | Check surroundings for ferrous objects or magnetic interference. Recalibrate the compass. Disable the compass assist in the ALTA App. |
| ALTA 8 circles a point in Position Mode                        | Compass calibration is invalid           | Recalibrate the compass   |
|  | Position Hold tuning values too high     | Reduce Position Hold tuning values, starting with Position Hold Strength  |

|   |   |   |
|---|---|---|
| ALTA 8 does not track straight in Position Mode | Compass calibration invalid                         | Perform a manual compass calibration.<br>Disable compass assist in the ALTA App if location has high magnetic flux or large ferrous objects                               |
| ALTA 8 does not Return-to-Home when commanded   | Position Lock not achieved                          | Monitor the ALTA App to ensure position lock has been achieved with strong GPS signal   |
|   | Incorrect initiation process                        | Set Mode switch to Position Mode.<br>Set Home switch to RTH.  |
| ALTA 8 does not enter Orbit mode when commanded | Position Lock not achieved                          | Monitor the ALTA App to ensure position lock has been achieved with strong GPS signal   |
|   | Incorrect initiation process                        | Set Mode switch to Position Mode.<br>Fly over the desired orbit point and toggle Orbit switch to set the center point. Fly to desired radius, and set Orbit switch to On. |
| ALTA 8 wobbles when descending                  | Vertical descent into turbulent air from propellers | Descend at a slight angle relative to vertical so the ALTA 8 does not fly into turbulent air from propeller downwash  |



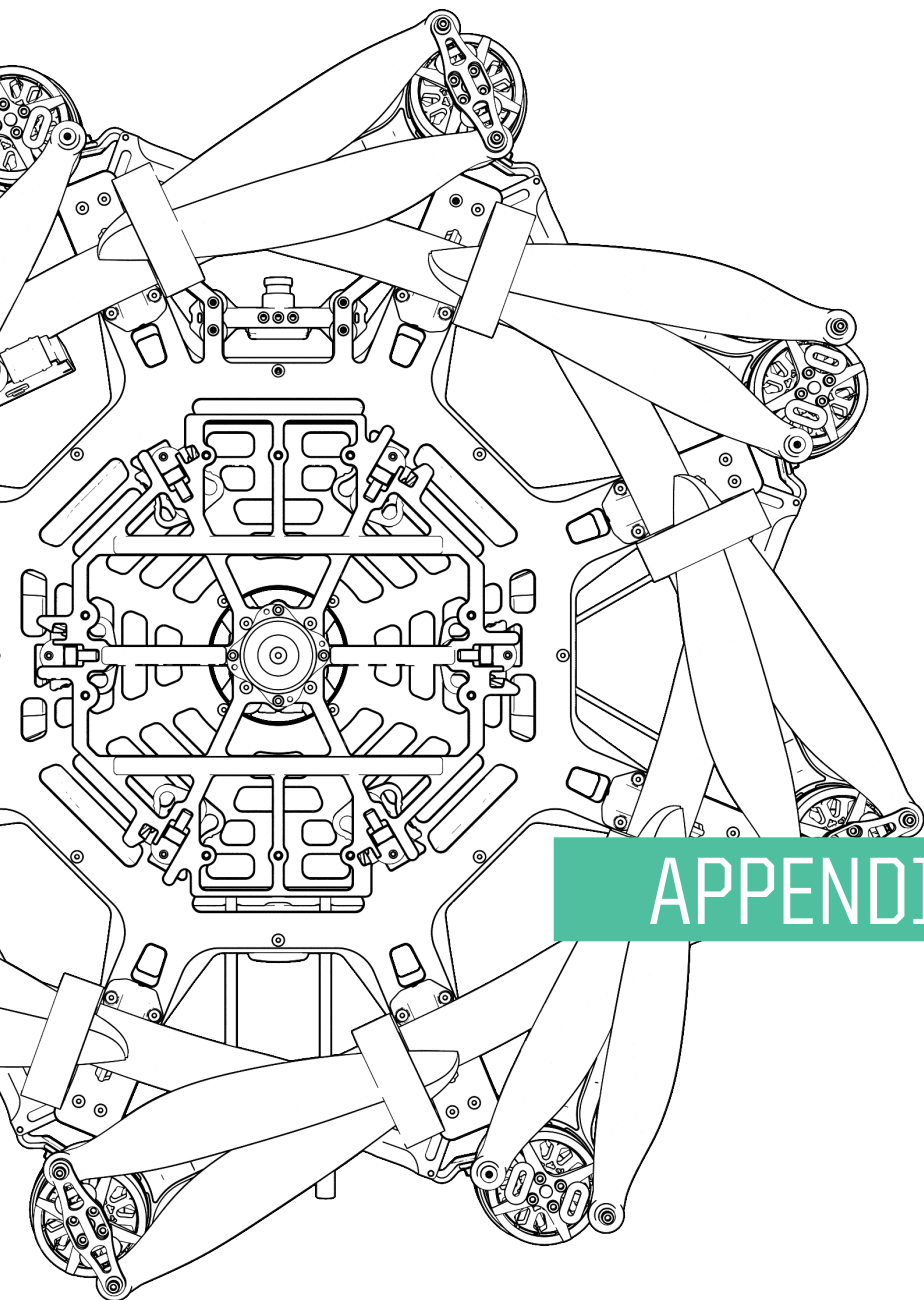

# APPENDIX

## APPENDIX A. DEFAULT TUNING VALUES

The following default tuning values only apply to ALTA 8. For ALTA 6 tuning values, refer to the ALTA 6 Aircraft Flight Manual.

| PARAMETER GROUP | PARAMETER                | DEFAULT VALUE   |
|-----------------|--------------------------|-----------------|
| Attitude        | Pitch/Roll Stiffness     | 65              |
|                 | Pitch/Roll Hold Strength | 50              |
|                 | Yaw Stiffness            | 140             |
|                 | Yaw Hold Strength        | 60              |
|                 | Roll Trim                | 0               |
|                 | Pitch Trim               | 0               |
|                 | Maximum Pitch/Roll Angle | 40°             |
|                 | Maximum Yaw Rate         | 100°/sec        |
| Height          | Vertical Stiffness       | 9               |
|                 | Hold Strength            | 80              |
|                 | Hover Throttle           | 14.0 volts      |
|                 | Climb Rate               | 3 meters/sec    |
| Position        | Horizontal Stiffness     | 35              |
|                 | Hold Strength            | 40              |
|                 | Maximum G                | 0.3             |
|                 | GPS Angle                | 30°             |
|                 | GPS Speed                | 5 meters/sec    |
|                 | Kinematic Mode           | Off             |
|                 | Kinematic Mass           | 7               |
| Safety          | Alarm Voltage            | 3.5 volts       |
|                 | Land Voltage             | 3.2 volts       |
|                 | Safe Height              | 15 meters       |
|                 | Autoland Descent Rate    | -0.8 meters/sec |
|                 | RTH Speed                | 3 meters/sec    |
|                 | Signal Loss Action       | Land            |
|                 | Motion Booting           | Off             |
|                 | Ceiling                  | 118 meters      |
|                 | Override Max Ceiling     | No              |
|                 | Range                    | 500 meters      |
|                 | Override Max Range       | No              |

## APPENDIX B. DATA LOGGING FIELDS

| FIELD                  | UNITS                        | DESCRIPTION   |
|------------------------|------------------------------|---|
| Reading                | unitless                     | An indexed identifier assigned to data points   |
| IMU Time               | seconds                      | The number of seconds from arming ALTA  |
| Date                   | YYYYMMDD                     | The date of the reading in Universal Coordinated Time determined by received GPS signals                |
| GPS Time               | HH:MM:SS                     | The Universal Coordinated Time determined by received GPS signals.                                      |
| GPS Longitude          | degrees * 10 <sup>7</sup>    | GPS determined longitude multiplied by 10 <sup>7</sup>  |
| GPS Latitude           | degrees * 10 <sup>7</sup>    | GPS determined latitude multiplied by 10 <sup>7</sup>   |
| GPS Height             | meters                       | Height above the WGS84 reference ellipsoid  |
| GPS Course             | degrees                      | The ground track of ALTA in degrees from true north.  |
| GPS Position North     | meters                       | The distance ALTA traveled north from the starting point. A negative number indicates southward travel. |
| GPS Position East      | meters                       | The distance ALTA traveled east from the starting point. A negative number indicates westward travel.   |
| GPS Position Up        | meters                       | The distance ALTA traveled above the starting point. A negative number indicates downward travel.       |
| GPS Velocity North     | meters / second              | The GPS derived northward velocity component of ALTA.   |
| GPS Velocity East      | meters / second              | The GPS derived eastward velocity component of ALTA.  |
| GPS Velocity Up        | meters / second              | The GPS derived upward velocity component of ALTA   |
| GPS Acceleration North | meters / second <sup>2</sup> | The GPS derived northward acceleration  |
| GPS Acceleration East  | meters / second <sup>2</sup> | The GPS derived eastward acceleration   |

|                              |                              |   |
|------------------------------|------------------------------|---|
| GPS Acceleration Up          | meters / second <sup>2</sup> | The GPS derived upward acceleration, without gravitational acceleration                   |
| IMU Position North           | meters                       | The IMU derived dead-reckoned distance ALTA has traveled northward                        |
| IMU Position East            | meters                       | The IMU derived dead-reckoned distance ALTA has traveled eastward                         |
| IMU Position Up              | meters                       | The IMU derived dead-reckoned distance ALTA has traveled upward                           |
| IMU Velocity North           | meters / second              | The IMU derived northward velocity component of ALTA.                                     |
| IMU Velocity East            | meters / second              | The IMU derived eastward velocity component of ALTA.                                      |
| IMU Velocity Up              | meters / second              | The IMU derived upward velocity component of ALTA.  |
| IMU Acceleration North       | meters / second <sup>2</sup> | The IMU derived northward acceleration  |
| IMU Acceleration East        | meters / second <sup>2</sup> | The IMU derived eastward acceleration   |
| IMU Acceleration Up          | meters / second <sup>2</sup> | The IMU derived upward acceleration, without gravitational acceleration                   |
| IMU Delay Acceleration North | meters / second <sup>2</sup> | The IMU derived northward acceleration, filtered  |
| IMU Delay Acceleration East  | meters / second <sup>2</sup> | The IMU derived eastward acceleration, filtered   |
| IMU Roll                     | degrees                      | The IMU derived roll angle where positive values indicate roll right                      |
| IMU Pitch                    | degrees                      | The IMU derived pitch angle where positive values indicate pitch up                       |
| IMU Yaw                      | degrees                      | The IMU derived yaw angle where positive values are eastward and negative values westward |
| IMU Roll Rate                | degrees / second             | The IMU derived roll rate where positive values are roll rightward                        |
| IMU Pitch Rate               | degrees / second             | The IMU derived pitch rate where positive values are pitch upward                         |
| IMU Yaw Rate                 | degrees / second             | The IMU derived yaw rate where positive values are clockwise looking down on the vehicle  |

|                            |                              |  |
|----------------------------|------------------------------|--|
| IMU Acceleration X         | g                            | The IMU derived body acceleration where positive values are in a forwards direction                                  |
| IMU Acceleration Y         | g                            | The IMU derived body acceleration where positive values are in a rightwards direction                                |
| IMU Acceleration Z         | g                            | The IMU derived body acceleration where positive values are in an upwards direction and excludes gravity             |
| Compass X                  | unitless                     | A component of a unit magnetic vector with positive values directed to the front when front is pointing Northward    |
| Compass Y                  | unitless                     | A component of a unit magnetic vector with positive values directed to the right when front is pointing Westward     |
| Compass Z                  | unitless                     | A component of a unit magnetic vector with positive values directed to down when the underside is pointing Northward |
| Compass Heading            | degrees                      | The magnetic heading derived from the compass  |
| Position Command North     | meters                       | The position control loop set point in a Northerly direction referenced to take-off location                         |
| Position Command East      | meters                       | The position control loop set point in an Easterly direction referenced to take-off location                         |
| Position Command Up        | meters                       | The position control loop set point in an Upwards direction referenced to the take-off location                      |
| Velocity Command North     | meters / second              | The velocity control loop set point in an Northwards direction   |
| Velocity Command East      | meters / second              | The velocity control loops set point in an Eastwards direction   |
| Velocity Command Up        | meters / second              | The velocity control loop set point in an Upwards direction  |
| Acceleration Command North | meters / second <sup>2</sup> | The acceleration control loop set point in a Northerly direction   |
| Acceleration Command East  | meters / second <sup>2</sup> | The acceleration control loop set point in a Easterly direction  |
| Acceleration Command Up    | meters / second <sup>2</sup> | The acceleration control loop set point in an Upwards direction  |

|                      |                                |  |
|----------------------|--------------------------------|--|
| Roll Command         | degrees                        | The roll control loop set point where increasing values are roll right   |
| Pitch Command        | degrees                        | The pitch control loop set point where increasing values are pitch up  |
| Yaw Command          | degrees                        | The yaw control loop set point where positive values are for an Easterly heading and negative for Westerly   |
| Roll Rate Command    | degrees / second               | The roll rate control loop set point where positive values are for rolling rightwards  |
| Pitch Rate Command   | degrees / second               | The pitch rate control loop set point where positive values are for pitching upwards   |
| Yaw Rate Command     | degrees / second               | The yaw rate control loop set point where positive values are rotating clockwise looking from the machine top  |
| Radio Roll           | microseconds ( $\mu\text{s}$ ) | RC pulse width 1000-2000 $\mu\text{s}$ where increasing values are for roll right  |
| Radio Pitch          | microseconds ( $\mu\text{s}$ ) | RC pulse width 1000-2000 $\mu\text{s}$ where increasing values are for pitch up  |
| Radio Yaw            | microseconds ( $\mu\text{s}$ ) | RC pulse width 1000-2000 $\mu\text{s}$ where increasing values are for yaw to the right  |
| Radio Throttle       | microseconds ( $\mu\text{s}$ ) | RC pulse width 1000-2000 $\mu\text{s}$ where increasing values are for increased throttle  |
| Radio Mode           | microseconds ( $\mu\text{s}$ ) | RC pulse width 1000-2000 $\mu\text{s}$ where values near:<br>1000 $\mu\text{s}$ = manual mode<br>1500 $\mu\text{s}$ = height hold<br>2000 $\mu\text{s}$ = height and position hold |
| Radio Home           | microseconds ( $\mu\text{s}$ ) | RC pulse width 1000-2000 $\mu\text{s}$ where values near:<br>2000 $\mu\text{s}$ = Set New Home Position<br>1500 $\mu\text{s}$ = RTH Off<br>1000 $\mu\text{s}$ = Initiate RTH       |
| Radio Velocity Clamp | microseconds ( $\mu\text{s}$ ) | RC pulse width 1000-2000 $\mu\text{s}$ where increasing values are for increased allowable velocity  |

|                        |                                |   |
|------------------------|--------------------------------|---|
| Radio Climb Rate Clamp | microseconds ( $\mu\text{s}$ ) | RC pulse width 1000-2000 $\mu\text{s}$ where increasing values are for increased allowable climb rate   |
| Safety Disarm          | microseconds ( $\mu\text{s}$ ) | RC pulse width 1000-2000 $\mu\text{s}$ where values near:<br>1000 $\mu\text{s}$ = Off - Disarming possible<br>1500 $\mu\text{s}$ = Off - Disarming possible<br>2000 $\mu\text{s}$ = On - Disarming not possible |
| Target                 | microseconds ( $\mu\text{s}$ ) | RC pulse width 1000-2000 $\mu\text{s}$ where values near:<br>1000 $\mu\text{s}$ = Set Orbit Center Point<br>1500 $\mu\text{s}$ = Orbit Off<br>2000 $\mu\text{s}$ = Orbit On                                     |
| Roll Control           | unitless                       | Control loop calculation for roll axis  |
| Pitch Control          | unitless                       | Control loop calculation for pitch axis   |
| Yaw Control            | unitless                       | Control loop calculation for yaw axis   |
| Climb Control          | unitless                       | Control loop calculation for lifting thrust   |
| Motor Command 1-8      | unitless                       | Scaled 0-1 representing demanded thrust from motor  |
| Motor speed 1-8        | revolutions per minute (rpm)   | Propeller speed at last telemetry update  |
| Motor Voltage 1-8      | Volts                          | Bus voltage measured at ESC from last telemetry update  |
| Motor Current 1-8      | Amps                           | Motor field current measured at ESC from last telemetry update  |
| Motor Power 1-8        | Watts                          | Measured ESC power consumption  |
| Motor Energy 1-8       | Watt-hours                     | Integrated ESC power consumption - can be used to compare motor efficiencies or thrust skew   |
| Motor Accel 1-8        | unitless                       | High pass filtered RMS vibration level measured at ESC - can be used to compare motor / propeller imbalance   |
| Motor Temp 1-8         | $^{\circ}\text{C}$             | ESC temperature measured from last telemetry update   |
| Motor Status 1-8       | bit-field                      | ESC fault condition monitor. Status 0 indicates no errors.  |
| GPS Sats               | integer                        | Number of satellites used for position calculation by GPS   |

|                             |                 |   |
|-----------------------------|-----------------|---|
| GPS Hacc                    | meters          | Horizontal position accuracy reported by GPS  |
| GPS Sacc                    | meters / second | Horizontal speed accuracy reported by GPS   |
| GPS Jamming Indicator       | unitless        | Indicator of GPS signal jamming activity with 0 = no jamming and 255 = strong jamming   |
| Voltage                     | Volts           | Main battery voltage measured by the flight controller  |
| Current                     | Amps            | Total battery current inferred from ESC measurements  |
| Capacity                    | Amp-Hours       | Integrated battery capacity consumed - to be used in conjunction with battery recharge measurements - ascertaining battery health and expected flight times |
| Power                       | Watts           | Total battery power   |
| Energy                      | Watt-hours      | Integrated battery power - to be used in conjunction with battery recharge measurements - ascertaining battery health and expected flight times             |
| 5V Monitor                  | Volts           | Measured voltage of the 5 volts bus   |
| Microcontroller Temperature | °C              | Flight controller PCB temperature   |
| Barometer Temperature       | °C              | Barometric sensor temperature   |
| Barometric Altitude         | meters          | Height above take-off location derived by pressure measurement  |
| Status                      | unitless        | Flight controller status<br>0 - Boot<br>1 - Alive<br>2 - Rearm<br>3 - Armed<br>4 - Flying<br>5 - Autoland   |
| Fail                        | bitfield        | Machine alarm register indicating particular system failures. Status 0 indicates no failures.   |
| GPS Loss of Signal          | boolean         | Declared if GPS signal is not adequate for safe position hold   |



|                        |                              |   |
|------------------------|------------------------------|---|
| Radio Loss of Signal   | boolean                      | Indicates complete radio controller loss of signal                      |
| Radio A Loss of Signal | number                       | Indicates accumulated loss of signal from radio A                       |
| Radio B Loss of Signal | number                       | Indicates accumulated loss of signal from radio B                       |
| Magnetometer Bad       | boolean                      | Alarm indicating compass magnitude is corrupted                         |
| Battery Flat           | boolean                      | Indicates if the low voltage alarm is active                            |
| Motors Hot             | boolean                      | Indicates if the motor temperature alarm is active                      |
| KF Lock                | boolean                      | Status indicating position estimation filter has locked (Position Lock) |
| Heading Lock           | boolean                      | Status indicating heading lock is active                                |
| Attitude Mode          | register                     | Status indicating angle or rate control mode                            |
| Position Mode          | register                     | Status indicating position control mode                                 |
| Height Mode            | register                     | Status indicating height control mode                                   |
| Target Mode            | register                     | Status indicating orbit control mode                                    |
| CRC Failures           | number                       | Internal communication errors   |
| I2C Timeouts           | number                       | Count of the number of internal I2C communication bus drops             |
| CAN Fails              | number                       | Count of the number of failures within the CAN communication bus        |
| Global CAN Fails       | number                       | Count of the number of failures of the entire CAN communication bus     |
| Gyro Bias R            | number                       | Arbitrary number indicating roll gyro bias                              |
| Gyro Bias P            | number                       | Arbitrary number indicating pitch gyro bias                             |
| Gyro Bias Y            | number                       | Arbitrary number indicating yaw gyro bias                               |
| Accel Bias X           | meters / second <sup>2</sup> | Accelerometer X axis bias   |
| Accel Bias Y           | meters / second <sup>2</sup> | Accelerometer Y axis bias   |
| Accel Bias Z           | meters / second <sup>2</sup> | Accelerometer Z axis bias   |
| Extended Status        | bitfield                     | Status of extended internal alarms                                      |
| 5V Alarm               | boolean                      | Indicates a failure of the 5 volt bus                                   |

|             |        |  |
|-------------|--------|--|
| Z Vibration | g      | Parameter used for monitoring the health and control of ALTA |
| Checksum    | number | Parameter recorded to detect errors in data recording        |